

EN



SPARE PARTS LIST

Cargotec Korea Ltd

Instruction

This spare parts catalogue has several main divisions each embracing a main component group, where you can find easily the necessary part.

Each drawing is followed by the corresponding written material Parts shown in the drawings are numbers by position starting from 1, drawings are numbered as;

(page numbering)

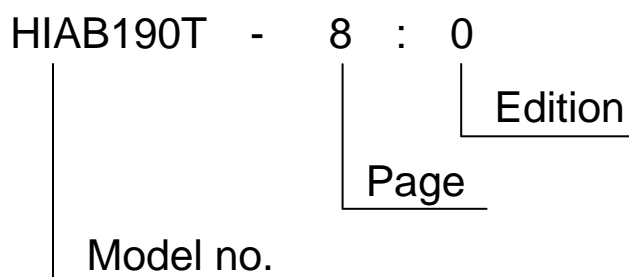

The position number is listed with written part number, description, quantity and specification / remarks.

When ordering spare parts, please inform;

1. Model no.
2. Page numbering
3. Part number & description
4. Quantity
5. Your complete address

This spare parts catalogue can be changed without prior notice will be informed accordingly.



주요 부분 지시도
MAIN SUBDIVISIONS

HIAB190T-6 0 : 0
2013. 01.

-	주요 부품 지시도 MAIN SUBDIVISIONS	HIAB190T-6 - 0 : 0	11	카운터 발란스 밸브 COUNTER BALANCE VALVE (S)	HIAB190T-6 - 11 : 0
1	크레인 총 결합도 HIAB190T-6 TOTAL ASS'Y	HIAB190T-6 - 1 : 0	12	쉬브 결합체 SHEAVE ASS'Y	HIAB190T-6 - 12 : 0
2	베이스 및 컬럼 결합체 BASE & COLUMN ASS'Y	HIAB190T-6 - 2 : 0	13	윈치 장치 WINCH SYSTM	HIAB190T-6 - 13 : 0
3	베이스 배관도 BASE HOSE & PIPING	HIAB190T-6 - 3 : 0	14	선회 감속기 SLEWING REDUCER	HIAB190T-6 - 14 : 0
4	제어 장치 CONTROL SYSTEM	HIAB190T-6 - 4 : 0	15	선회 모터 SLEWING MOTOR	HIAB190T-6 - 15 : 0
5	아웃트리거 제어 밸브 OUTRIGGER CONTROL VALVE	HIAB190T-6 - 5 : 0	16	카운터 발란스 밸브 COUNTER BALANCE VALVE (D)	HIAB190T-6 - 16 : 0
6	붐 장치 BOOM SYSTEM	HIAB190T-6 - 6 : 0	17	데릭 실린더 DERRICK CYLINDER	HIAB190T-6 - 17 : 0
7	신축 붐 실린더 EXTENSION BOOM CYLINDER	HIAB190T-6 - 7 : 0	18	로타리 조인트 결합체 ROTARY JOINT ASS'Y	HIAB190T-6 - 18 : 0
8	1단 신축 실린더 1st EXTENSION CYLINDER	HIAB190T-6 - 8 : 0	19	운전석 결합체 TOP SEAT ASS'Y	HIAB190T-6 - 19 : 0
9	2단 신축 실린더 2nd EXTENSION CYLINDER	HIAB190T-6 - 9 : 0	20	운전석 배관도 TOP SEAT HOSES	HIAB190T-6 - 20 : 0
10	3단 신축 실린더 3rd EXTENSION CYLINDER	HIAB190T-6 - 10 : 0	21	주 제어 밸브 MAIN CONTROL VALVE	HIAB190T-6 - 21 : 0

SPARE PARTS LIST



주요 부분 지시도
MAIN SUBDIVISIONS

HIAB190T-6 0 : 0
2013. 01.

22	아웃트리거 장치 OUTRIGGER SYSTEM	HIAB190T-6 - 22 : 0
23	아웃트리거 실린더 OUTRIGGER CYLINDER	HIAB190T-6 - 23 : 0
24	사이드 쉬프트 실린더 SIDE SHIFT CYLINDER	HIAB190T-6 - 24 : 0
25	파일로트 체크 밸브 VALVE, PILOT CHECK (D)	HIAB190T-6 - 25 : 0
26	후방 아웃트리거 결합체 (옵션) REAR OUTRIGGER ASS'Y (OPTION)	HIAB190T-6 - 26 : 0
27	후방 아웃트리거 실린더 (옵션) REAR OUTRIGGER CYLINDER (OPTION)	HIAB190T-6 - 27 : 0
28	후방 사이드 쉬프트 실린더 (옵션) REAR SIDE SHIFT CYLINDER (OPTION)	HIAB190T-6 - 28 : 0
29	파일로트 체크 밸브 (옵션) VALVE, PILOT CHECK (D) (OPTION)	HIAB190T-6 - 29 : 0
30	전기 배선도 ELECTRIC WIRING DIAGRAM	HIAB190T-6 - 30 : 0
31	스티커 배열 STICKER ARRANGMENT	HIAB190T-6 - 31 : 0
32	오일 탱크 결합체 OIL TANK ASS'Y	HIAB190T-6 - 32 : 0

SPARE PARTS LIST



크레인 총 결합체
HIAB190T TOTAL ASS'Y

HIAB190T-6 1 : 0
2013. 01.

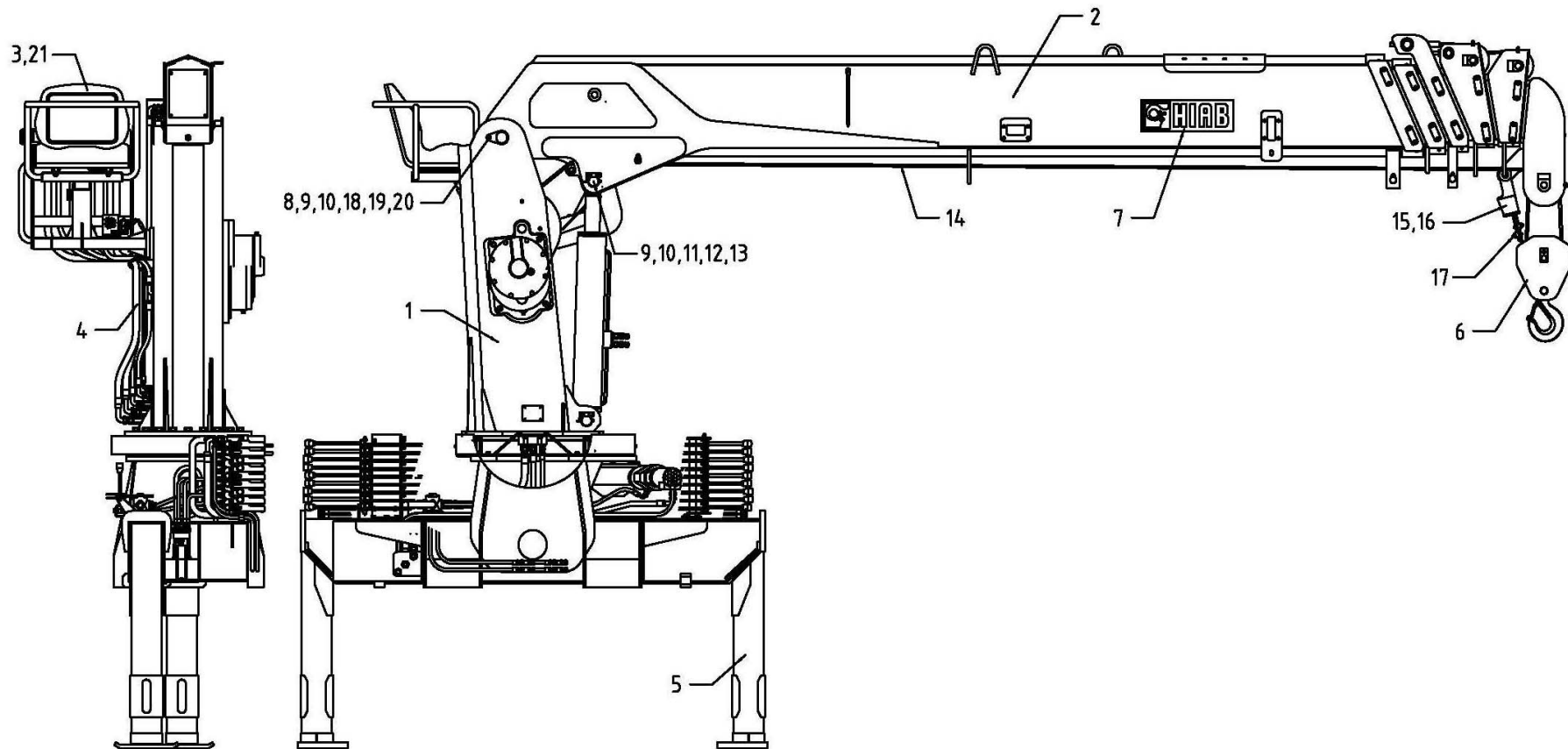

SPARE PARTS LIST



크레인 총 결합체
HIAB190T TOTAL ASS'Y

HIAB190T-6 1:0
2013. 01.

번호 No.	부품 번호 Part No.	품명 Description	수량 Q'ty	비고 Remarks	번호 No.	부품 번호 Part No.	품명 Description	수량 Q'ty	비고 Remarks
-	A00-0426	크레인 총 결합도 HIAB 190T TOTAL ASSY	1		11	TA1-0002	축 SHAFT	1	
1	A01-3596	베이스 및 칼럼 결합체 BASE & COLUMN ASSY	1		12	1311941	분할 핀 PIN, SPLIT	1	
2	A01-3540	붐 장치 BOOM SYSTEM	1		13	BC2-0005	플레이트 PLATE	1	
3	A01-0538	운전석 결합체 TOP SEAT ASSY	1		14	S01-5169	와이어 로프 ROPE, WIRE	1	Φ11.2×110m
4	A01-0795	운전석 배관도 TOP SEAT HOSES	1		15	A02-1264	소켓 결합체 SOCKET ASS'Y	1	
5	OR1-4001	아우트리거 장치 OUTRIGGER SYSTEM	1		16	S01-0002	록 핀 PIN, LOCK	1	
6	A02-2565	쉬브 결합체 SHEAVE ASSY	1		17	N01-1722	와이어 클립 CLIP, WIRE	4	
7	A01-3270	스티커 배열 STICKER, ARRANGEMENT	1		18	TA-6002	플레이트 PLATE	1	
8	TA1-0003	축 SHAFT	1		19	2111537	육각 머리 볼트 BOLT, HEX. HEAD	1	
9	2111226	육각 볼트 BOLT, HEX. HEAD	2		20	3612121	스프링 와셔 WASHER, SPRING	1	
10	3613101	스프링 와셔 WASHER, SPRING	2		21	E00-0116	전기 와이어 배선 ELECTRIC WIRE DIAGRAM	2	

SPARE PARTS LIST



베이스 및 칼럼 결합체
BASE & COLUMN ASS'Y

HIAB190T-6 2 : 0
2013. 01.

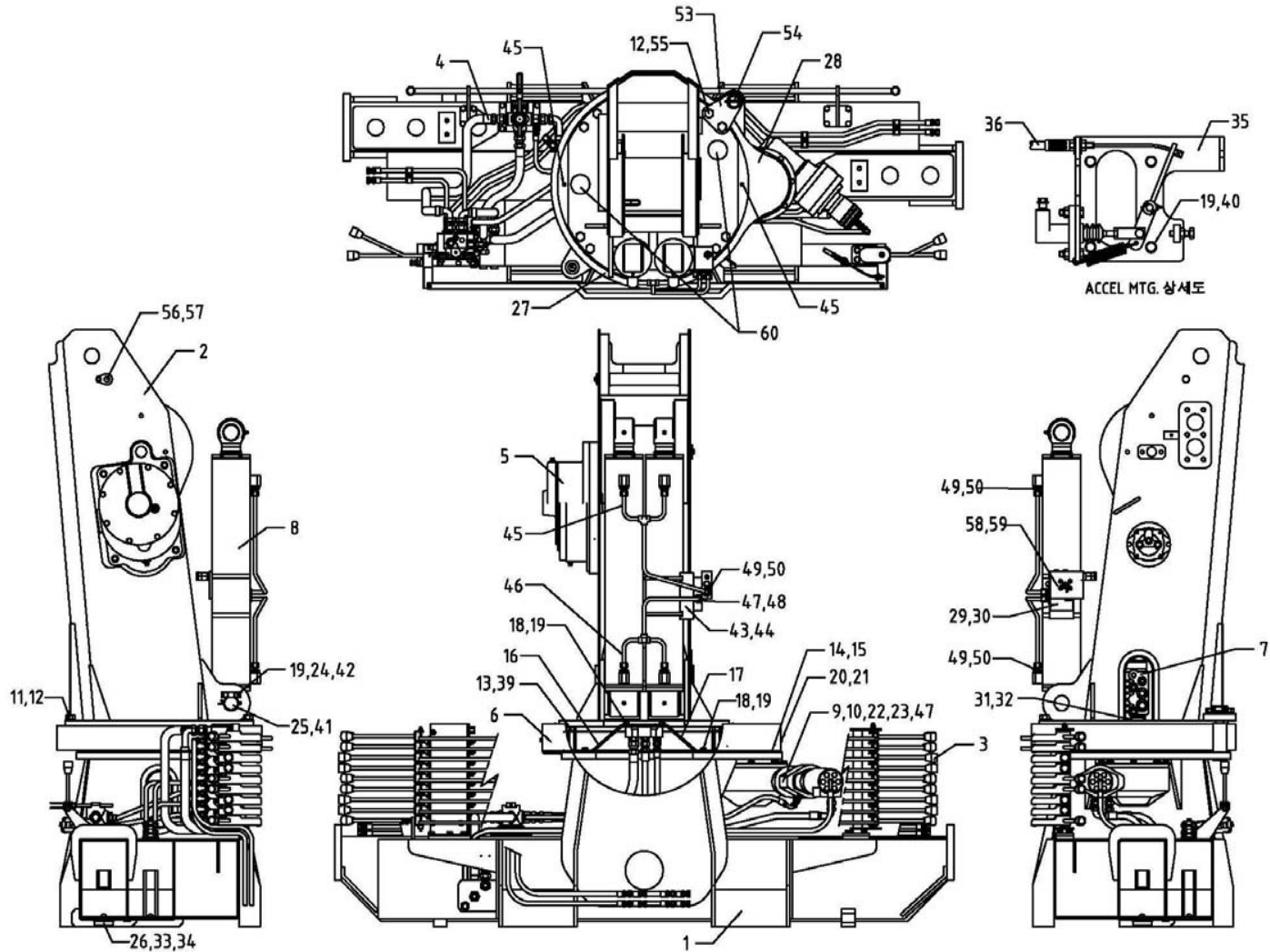

SPARE PARTS LIST



베이스 및 칼럼 결합체
BASE & COLUMN ASS'Y

HIAB190T-6 2 : 0
2013. 01.

번호 No.	부품 번호 Part No.	품명 Description	수량 Q'ty	비고 Remarks	번호 No.	부품 번호 Part No.	품명 Description	수량 Q'ty	비고 Remarks
-	A01-3596	베이스 & 칼럼 결합체 BASE & COLUMN ASS'Y	1		10	H02-0200	선회 모터 MOTOR, SLEWING	1	OMP100C
1	A02-3315	베이스 결합체 BASE ASS'Y	1		11	S01-1306	육각 볼트 BOLT, HEX. HEAD	13	BA20×60(12.9T)
2	A02-3690	칼럼 결합체 COLUMN ASS'Y	1		12	3612201	스프링 와셔 WASHER, SPRING	33	WS20
3	A02-3393	컨트롤 시스템 CONTROL SYSTEM	1		13	S01-1287	육각 볼트 BOLT, HEX. HEAD	8	BA20×110(12.9T)
4	A02-3402	베이스 호스 결합체 BASE HOSE ASS'Y	1		14	2112157	육각 볼트 BOLT, HEX. HEAD	7	BA16×45
5	WC-4001	윈치 시스템 WINCH SYSTEM	1		15	3612161	스프링 와셔 WASHER, SPRING	7	WS16
6	BC2-0002	선회 베어링 BEARING, SLEWING	1		16	W01-3737	브라켓 BRACKET	1	t=6
7	A02-1740	로타리 조인트 결합체 ROTARY JOINT ASS'Y	1		17	W01-3738	브라켓 BRACKET	1	t=6
8	H01-5001	데릭 실린더 결합체 DERRICK CYLINDER ASS'Y	2		18	2111226	육각 볼트 BOLT, HEX. HEAD	8	BA10×30
9	BC1-0003	선회 감속기 REDUCER, SLEWING	1		19	3612101	스프링 와셔 WASHER, SPRING	14	WS10

SPARE PARTS LIST



베이스 및 칼럼 결합체
BASE & COLUMN ASS'Y

HIAB190T-6 2 : 0
2013. 01.

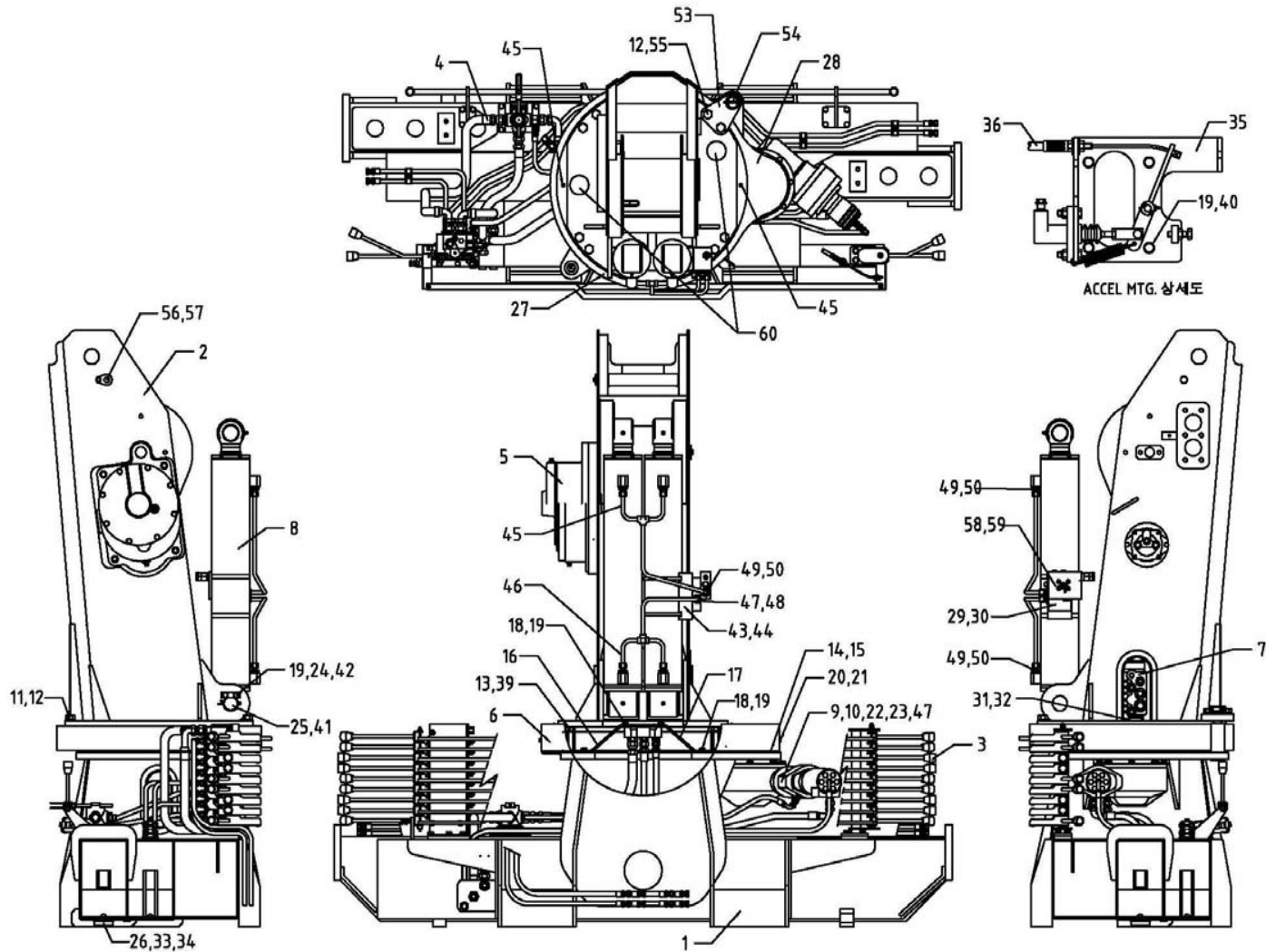

SPARE PARTS LIST



베이스 및 칼럼 결합체
BASE & COLUMN ASS'Y

HIAB190T-6 2 : 0
2013. 01.

번호 No.	부품 번호 Part No.	품명 Description	수량 Q'ty	비고 Remarks	번호 No.	부품 번호 Part No.	품명 Description	수량 Q'ty	비고 Remarks
20	2110447	육각 볼트 BOLT, HEX. HEAD	6	BA6×12	30	2610926	육각 구멍볼이 볼트 BOLT, HEX. SOCKET HEAD	2	BB8×30
21	3612061	스프링 와셔 WASHER, SPRING	10	WS6	31	M05-2435	브라켓 BRACKET	1	t=12
22	2111537	육각 볼트 BOLT, HEX. HEAD	2	BA12×35	32	BO-0005	접시 머리 볼트 BOLT, FLAT HEAD	3	M10×35
23	3612121	스프링 와셔 WASHER, SPRING	2	WS12	33	OR-0062	어저스트 볼트 BOLT, ADJUST	2	M52×P3.0
24	2111196	육각 볼트 BOLT, HEX. HEAD	2	BA10×22	34	OR-0063	어저스트 패드 PAD, ADJUST	2	
25	BC2-0004	축 SHAFT	1	55×348	35	BC1-8002	악셀 마운팅 결합체 ACCEL MOUNTING ASS'Y	1	
26	2340576	스크루 세트 SCREW SET (STICK END)	2	BM8×12	36	A02-1283	악셀 케이블 결합체 ACCEL CABLE ASS'Y	1	1700L
27	A05-1825	커버 (왼쪽) COVER (L.H)	1		37	4620702	그리이스 니플 NIPPLE, GREASE	2	B-PT1/8
28	A05-1827	커버 (오른쪽) COVER (R.H)	1		38	S01-0469	가스켓 GASKET	1	t=3.2
29	M01-1482	블록 BLOCK	1	CAEG-LJN	39	S01-1286	육각 볼트 BOLT, HEX. HEAD	10	BA20×100

SPARE PARTS LIST



베이스 및 칼럼 결합체
BASE & COLUMN ASS'Y

HIAB190T-6 2 : 0
2013. 01.

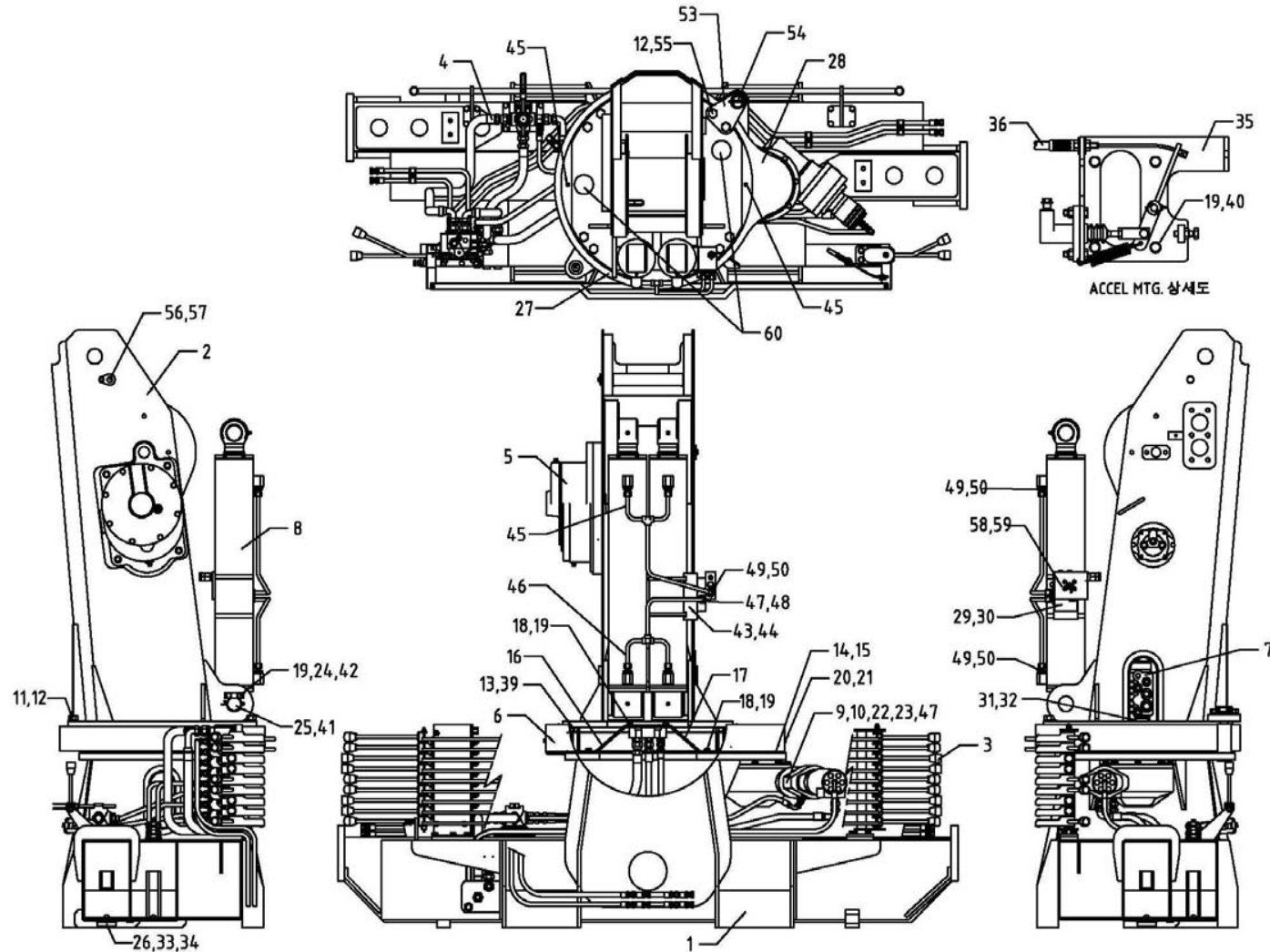

SPARE PARTS LIST



베이스 및 칼럼 결합체
BASE & COLUMN ASS'Y

HIAB190T-6 2:0
2013. 01.

번호 No.	부품 번호 Part No.	품명 Description	수량 Q'ty	비고 Remarks	번호 No.	부품 번호 Part No.	품명 Description	수량 Q'ty	비고 Remarks
40	2111166	육각 볼트 BOLT, HEX. HEAD	4	BA10×16	51	2110886	육각 볼트 BOLT, HEX. HEAD	1	BA8×20
41	1311941	분할 핀 PIN, SPLIT	1	PW10×100	52	3612081	스프링 와셔 WASHER, SPRING	1	WS8
42	BC2-0005	플레이트 PLATE	1	t=9	53	M01-0856	플레이트 PLATE	1	t=25
43	BC2-0006	찬널 CHANNER	1	t=3.2	54	S01-2283	핀 PIN	1	
44	7811121	호스 클램프 CLAMP, HOSE	2	CH127	55	S01-1899	육각 볼트 BOLT, HEX. HEAD	2	BA20×80(12.9T)
45	H01-2325	유압 파이프 PIPE, HYDRAULIC	1	Φ12×t2.0	56	S01-2584	축 SHAFT	1	Φ25×340L
46	H01-2326	유압 파이프 PIPE, HYDRAULIC	1	Φ12×t2.0	57	A05-2307	롤러 결합체 ROLLER ASS'Y	1	
47	9003351	파이프 니플 NIPPLE, PF PIPE	1	NFO12-PF3/8	58	986 8381	로드 홀딩 밸브 VALVE, LOAD HOLDING	1	
48	6010172	오링 O-RING	1	1B P14	59	2615957	육각 구멍볼이 볼트 BOLT, HEX. SOCKET HEAD	4	BB8×45
49	9001361	파이프 니플 NIPPLE, PF PIPE	5	NFP12×PF1/2	60	S01-3371	커버 COVER, MC	2	Φ70×20L
50	6800081	실링 와셔 WASHER, SEALING	5	NF216-8					

SPARE PARTS LIST



베이스 배관도
BASE HOSE & PIPING

HIAB190T-6 3:0
2013. 01.

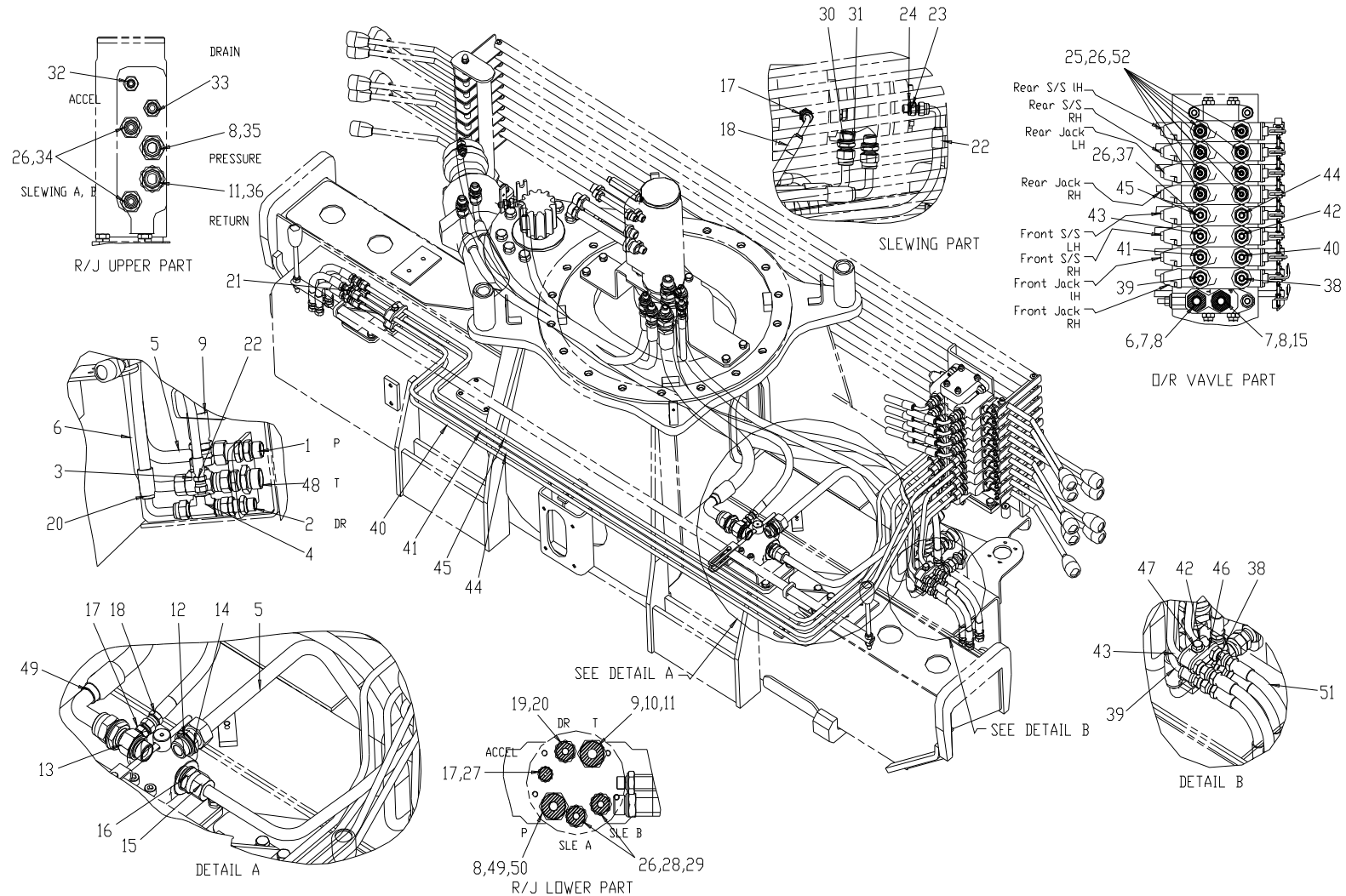

SPARE PARTS LIST



베이스 배관도
BASE HOSE & PIPING

HIAB190T-6 3 : 0
2013. 01.

번호 No.	부품 번호 Part No.	품 명 Description	수량 Q'ty	비 고 Remarks	번호 No.	부품 번호 Part No.	품 명 Description	수량 Q'ty	비 고 Remarks
-	A02-3402	베이스 호스 & 파이프 결합체 BASE HOSE & PIPE ASS'Y	1		10	9381092	호스 유니언 UNION, CONICAL	1	NFCO3/4×3/4
1	S01-5040	벌크 헤드 호스 유니언 UNION, HOSE B/H	1	Φ20×PF3/4	11	6010282	O-링 O-RING	2	P24
2	BP-4003	벌크 헤드 호스 유니언 UNION, HOSE B/H	1	2-PF1/2	12	6800121	GS 와셔 GS-WASHER	3	NF3/4
3	S01-5037	파이프 스윙블 티 TEE, PIPE SWIVEL	1	2-PF3/4×Φ16	13	S01-4674	니플 NIPPLE	1	PF3/4×PF1/4
4	S01-1608	호스 스윙블 티 TEE, HOSE SWIVEL	1	2-PF1/2×PF1/4	14	9001451	파이프 니플 NIPPLE, PF PIPE	1	20-PF3/4
5	H01-6651	유압 파이프 PIPE, HYDRAULIC	1	Φ20×t2.0	15	H01-6631	유압 파이프 PIPE, HYDRAULIC	1	Φ16×t2.0
6	H01-6652	유압 파이프 PIPE, HYDRAULIC	1	Φ16×t2.0	16	9001411	파이프 니플 NIPPLE, PF PIPE	1	16-PF3/4
7	9003401	파이프 니플 NIPPLE, PF PIPE	2	NTPO16-PF1/2	17	9211062	호스 니플 NIPPLE, PT HOSE	3	PF1/4×PT1/4
8	6010212	O-링 O-RING	4	P18	18	7167902	고압 호스 HOSE, H.P (HECF)	1	1/4×1250-PF1/4
9	7122833	고압 호스 HOSE, H.P (HUCF)	1	5/8×1080-PF3/4	19	TS-0439	호스 니플 NIPPLE, PT HOSE	1	PT3/8×PF1/2

SPARE PARTS LIST



베이스 배관도 BASE HOSE & PIPING

HIAB190T-6 3:0
2013. 01.

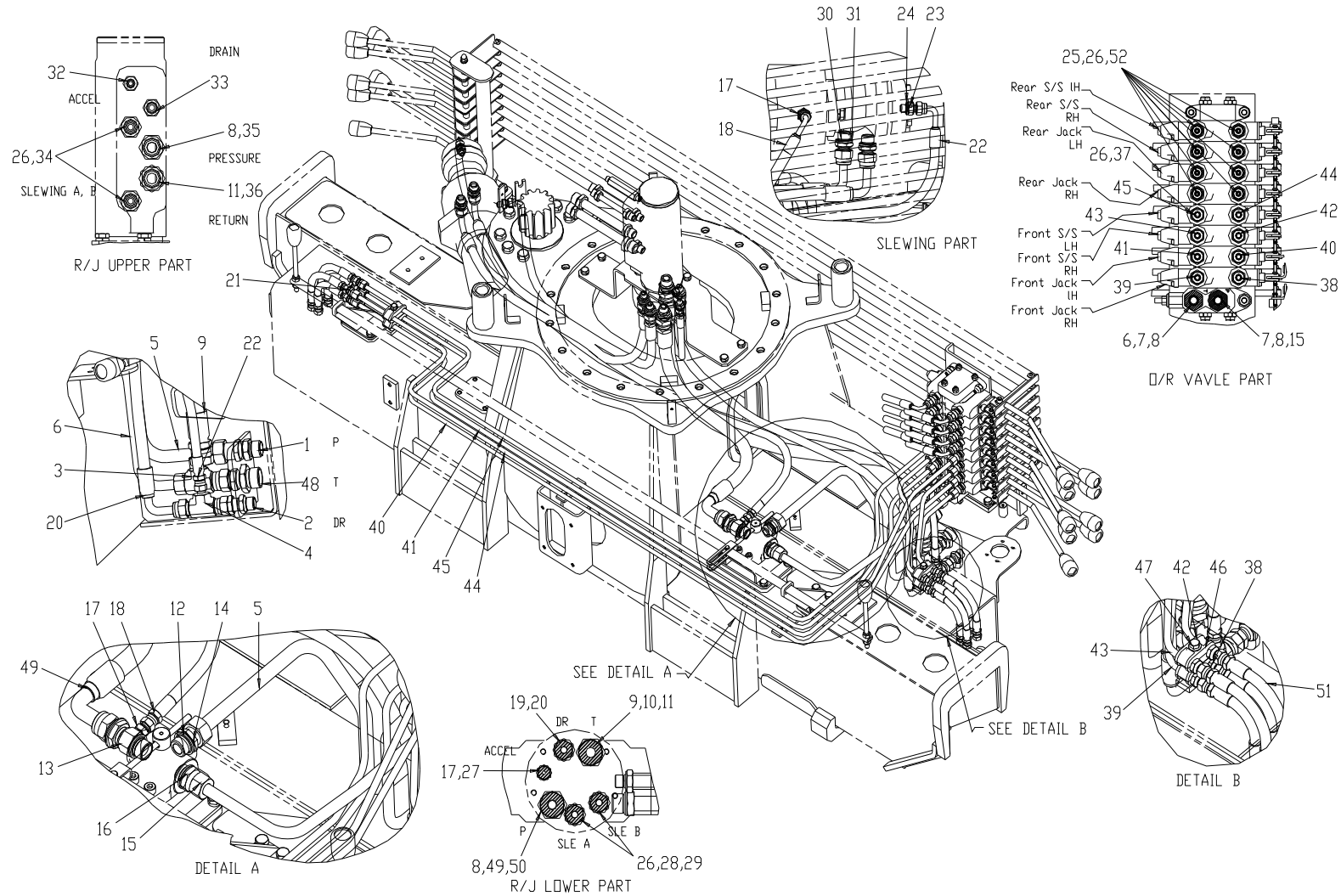

SPARE PARTS LIST



베이스 배관도
BASE HOSE & PIPING

HIAB190T-6 3:0
2013. 01.

번호 No.	부품 번호 Part No.	품명 Description	수량 Q'ty	비고 Remarks	번호 No.	부품 번호 Part No.	품명 Description	수량 Q'ty	비고 Remarks
20	7173843	고압 호스 HOSE, H.P (HECF)	1	1/2×1100-PF1/2	30	9270072	호스 유니언 UNION, CONICAL	2	1/2×1/2
21	9062032	호스 파이프 니플 NIPPLE, HOSE PIPE	4	10-PF1/4	31	6800081	GS 와셔 GS-WASHER	2	NF1/2
22	7168182	고압 호스 HOSE, H.P (HECF)	1	1/4×1950-PF1/4	32	BSP-0051	호스 니플 NIPPLE, PT HOSE	1	PT1/4×PF3/8
23	9270052	호스 유니언 UNION, CONICAL	1	1/4×1/4	33	BSP-0032	롱 니플 NIPPLE, LONG	1	PF3/8×PT3/8
24	6800041	GS 와셔 GS-WASHER	1	NF1/4	34	BSP-0033	롱 니플 NIPPLE, LONG	2	PF3/8×PF1/2
25	S01-0948	호스 니플 NIPPLE, PF HOSE	8	PF1/4(C)×PF3/8(O)	35	BSP-0034	롱 니플 NIPPLE, LONG	1	PF1/2×PF3/4
26	6010172	O-링 O-RING	20	P14	36	BSP-0035	롱 니플 NIPPLE, LONG	1	PF3/4×PF3/4
27	H01-1685	고압 호스 HOSE, H.P	1	1/4×1250-PF1/4	37	9003321	파이프 니플 NIPPLE, PF PIPE	8	NTPO10-PF3/8
28	9381052	호스 유니언 UNION, CONICAL	2	NFCO1/2×3/8	38	H01-6632	유압 파이프 PIPE, HYDRAULIC	1	Φ10×t1.5
29	7172313	고압 호스 HOSE, H.P (HECF)	2	3/8×1020-PF1/2	39	H01-6633	유압 파이프 PIPE, HYDRAULIC	1	Φ10×t1.5

SPARE PARTS LIST



베이스 배관도
BASE HOSE & PIPING

HIAB190T-6 3 : 0
2013. 01.

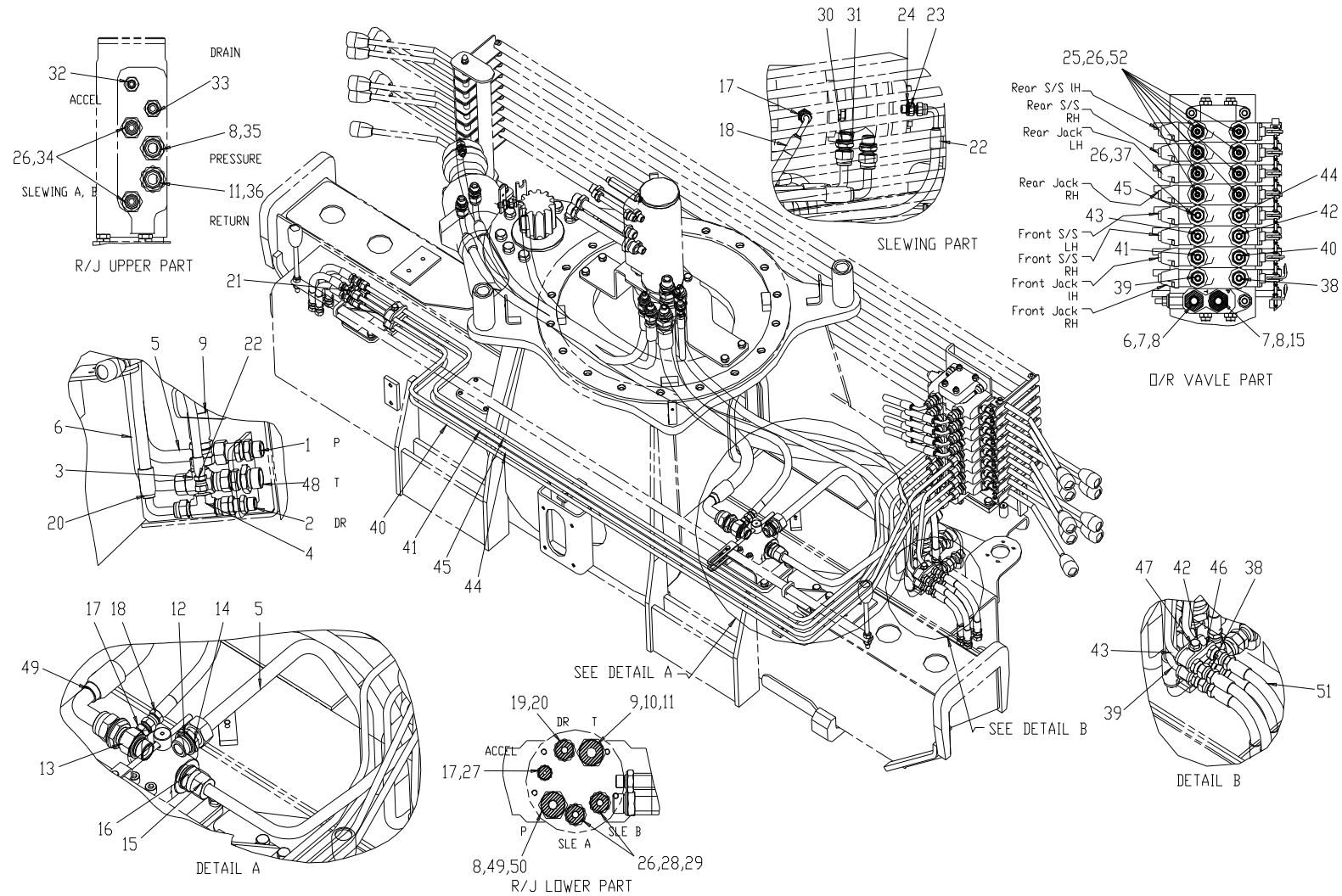

SPARE PARTS LIST



베이스 배관도
BASE HOSE & PIPING

HIAB190T-6 3:0
2013. 01.

번호 No.	부품 번호 Part No.	품명 Description	수량 Q'ty	비고 Remarks	번호 No.	부품 번호 Part No.	품명 Description	수량 Q'ty	비고 Remarks
40	H01-6634	유압 파이프 PIPE, HYDRAULIC	1	Φ10×t1.5	50	9381082	호스 유니언 UNION, CONICAL	1	NFCO3/4×1/2
41	H01-6635	유압 파이프 PIPE, HYDRAULIC	1	Φ10×t1.5	51	7113513	고압 호스 HOSE, H.P (HUCF)	8	1/4×300-PF1/4
42	H01-6636	유압 파이프 PIPE, HYDRAULIC	1	Φ10×t1.5	52	7167962	고압 호스 HOSE, H.P (HECF)	8	1/4×1400-PF1/4
43	H01-6637	유압 파이프 PIPE, HYDRAULIC	1	Φ10×t1.5					
44	H01-6638	유압 파이프 PIPE, HYDRAULIC	1	Φ10×t1.5					
45	H01-6639	유압 파이프 PIPE, HYDRAULIC	1	Φ10×t1.5					
46	S01-4269	클램프 CLAMP	8						
47	2185976	플렌지 볼이 육각 볼트 BOLT, HEX. HEAD W/F	2	BWF8×55					
48	S01-1755	벌크 헤드 호스 유니언 UNION, HOSE BULKHEAD	1	PF1×PF3/4					
49	7176683	고압 호스 HOSE, H.P (HECF)	1	5/8×650-PF3/4					

SPARE PARTS LIST



아우트리거 제어 장치 OUTRIGGER CONTROL SYSTEM

HIAB190T-6 4 : 0
2013. 01.

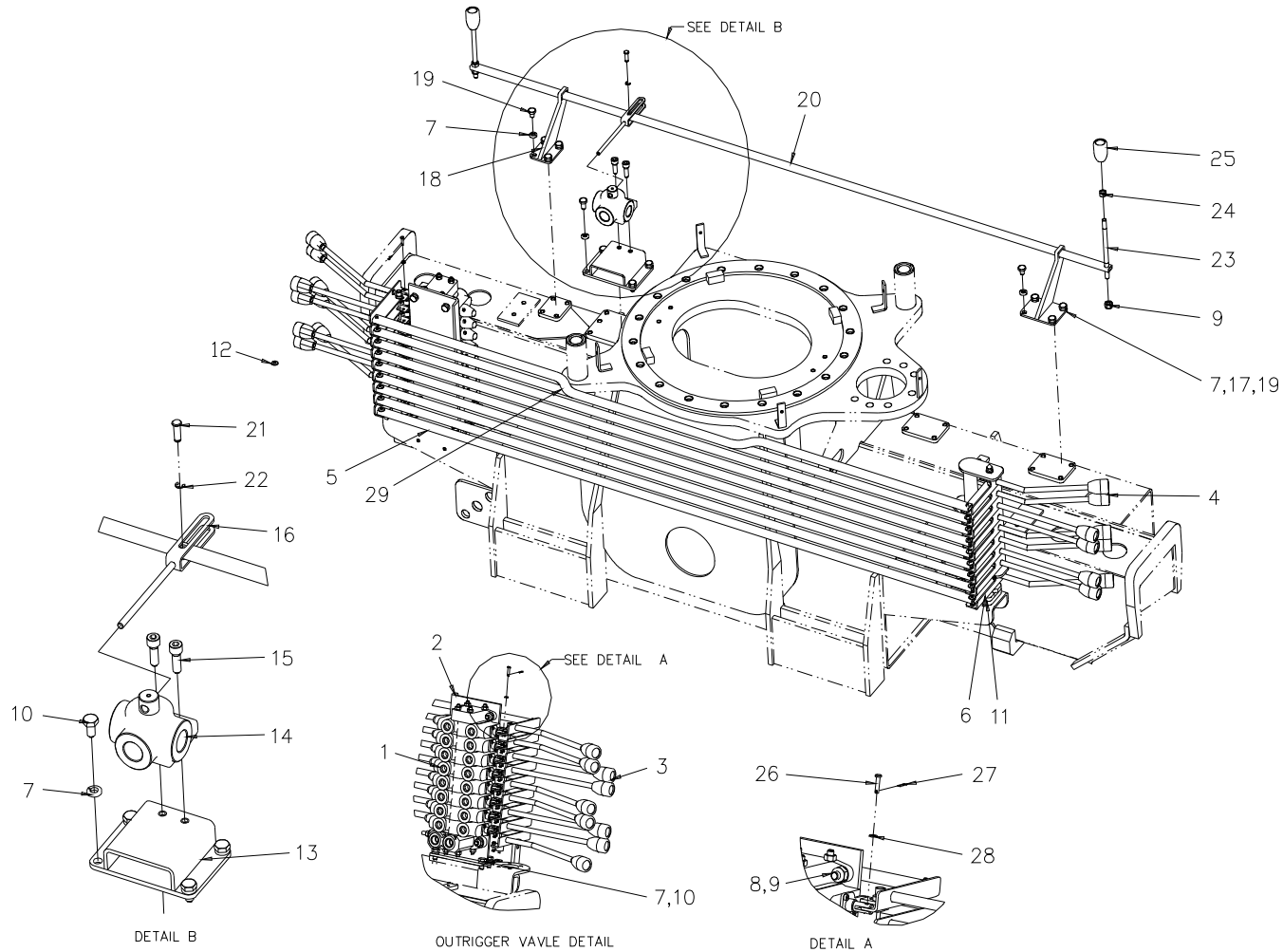

SPARE PARTS LIST



아우트리거 제어 장치
OUTRIGGER CONTROL SYSTEM

HIAB190T-6 4 : 0
2013. 01.

번호 No.	부품 번호 Part No.	품 명 Description	수량 Q'ty	비 고 Remarks	번호 No.	부품 번호 Part No.	품 명 Description	수량 Q'ty	비 고 Remarks
-	A02-3393	아우트리거 제어 장치 OUTRIGGER CONTROL SYSTEM	1		10	2111176	육각 머리 볼트 BOLT, HEX. HEAD	8	BA10×18
1	H02-1134	아우트리거 제어 밸브 VALVE, O/R CONTROL	1	TX50/8	11	2111206	육각 머리 볼트 BOLT, HEX. HEAD	4	BA10×25
2	A05-4026	브라켓트 결합체 BRACKET ASS'Y	1		12	S01-0854	백 와셔 WASHER, BACK	18	SPN06
3	A05-4027	아우트리거 레버 결합체 LEVER ASS'Y' O/R (1)	1		13	CT-6005	브라켓트 결합체 BRACKET ASS'Y	1	
4	A05-4028	아우트리거 레버 결합체 LEVER ASS'Y' O/R (2)	1		14	N01-2464	방향 전환 밸브 VALVE. DIVERTER	1	3WAY
5	M05-0967	로드 레버 ROD LEVER	8	t2.5×20×10	15	2611227	구멍볼이 육각 볼트 BOLT, HEX. SOCKET HEAD	2	BB10×30
6	3511101	평 와셔 WASHER, PLAIN	4	WP10	16	CT-3009	링크 LINK	1	
7	3612101	스프링 와셔 WASHER, SPRING	23	WS10	17	CT-6008	로드 브라켓트 결합체 ROD BRAKGET ASS'Y	1	
8	2111246	육각 머리 볼트 BOLT, HEX. HEAD	3	BA10×40	18	CT-6011	로드 브라켓트 결합체 ROD BRAKGET ASS'Y	1	
9	S01-0006	셀프 로킹 너트 NUT, SELF LOCKING	5	M10	19	2111146	육각 머리 볼트 BOLT, HEX. HEAD	8	BA10×12

SPARE PARTS LIST



아우트리거 제어 장치
OUTRIGGER CONTROL SYSTEM

HIAB190T-6 4 : 0
2013. 01.

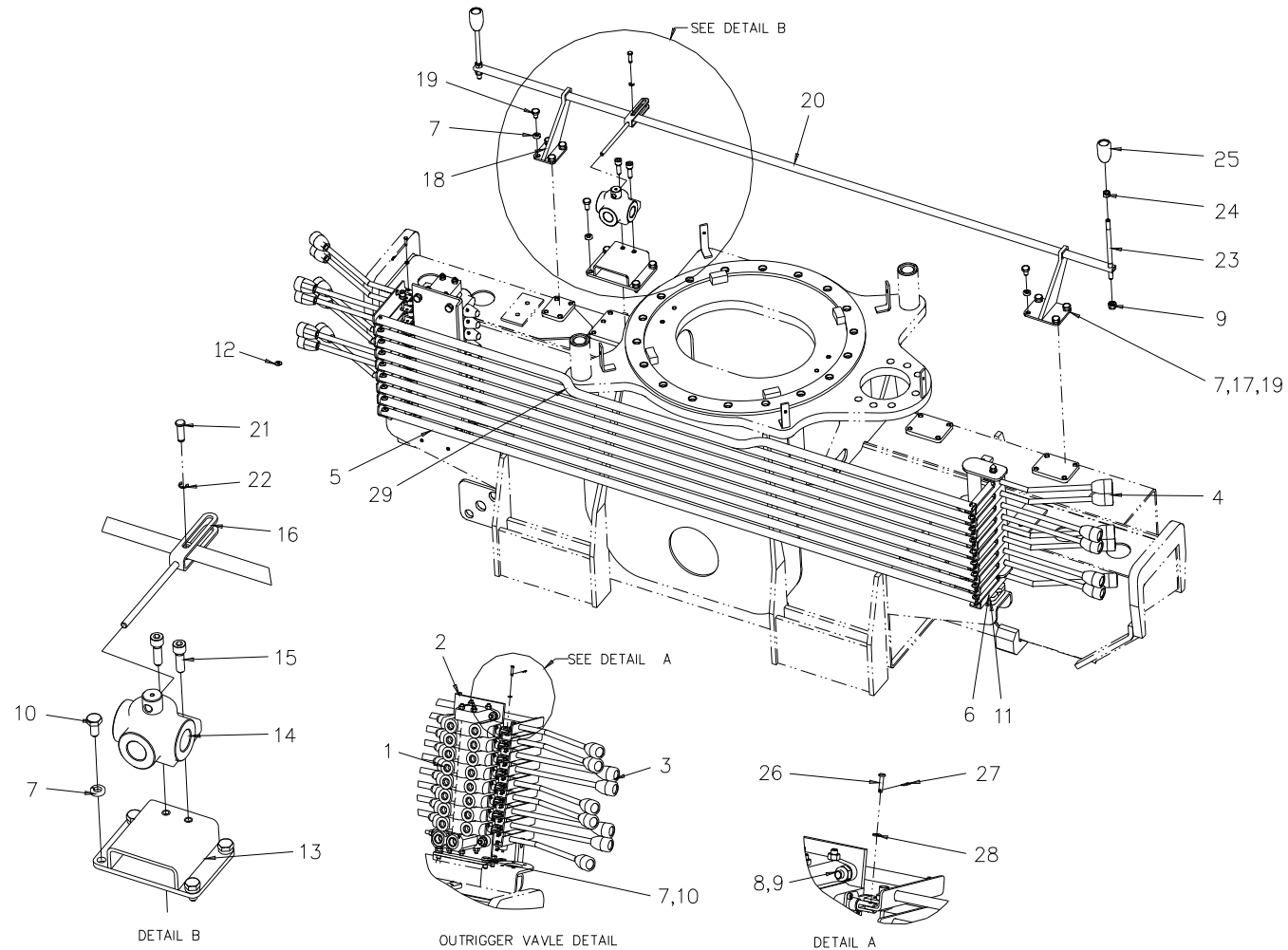

SPARE PARTS LIST



아우트리거 제어 장치
OUTRIGGER CONTROL SYSTEM

HIAB190T-6 4 : 0
2013. 01.

번호 No.	부품 번호 Part No.	품 명 Description	수량 Q`ty	비 고 Remarks	번호 No.	부품 번호 Part No.	품 명 Description	수량 Q`ty	비 고 Remarks
20	CT-3012	로드 레버 ROD LEVER	1	t2.5×10×20					
21	CT-4007	핀 PIN	1	Φ8×25					
22	4551091	멈춤 링 RING, RETAINING	1	RE6					
23	M01-0444	레버 LEVER	2	Φ10×173L					
24	3112106	육각 너트 NUT, HEX.	2	NA10					
25	S01-0048	손잡이 KNOB (RED)	2						
26	CS-0008	핀 PIN	9	Φ4.5×20					
27	CS-0009	싱글 스프링 핀 SPRING PIN, SINGLE	9	Φ1×15					
28	3511051	평 와셔 WASHER, PLAIN	9	WP5					
29	M05-0865	로드 레버 ROD LEVER	1	t1.6×12×23					

SPARE PARTS LIST



아우트리거 제어 밸브
OUTRIGGER CONTROL VALVE

HIAB190T-6 5 : 0
2013. 01.

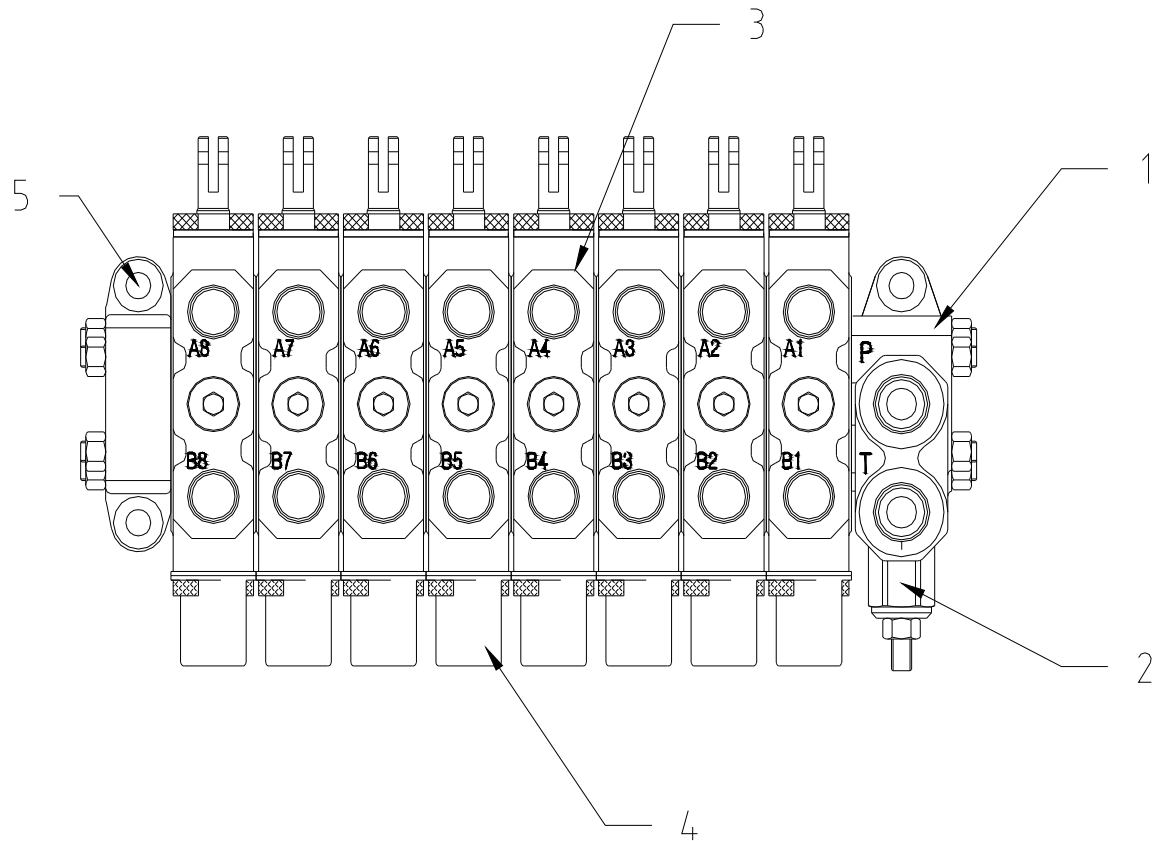

SPARE PARTS LIST



아우트리거 제어 밸브
OUTRIGGER CONTROL VALVE

HIAB190T-6 5 : 0
2013. 01.

번호 No.	부품 번호 Part No.	품 명 Description	수량 Q'ty	비 고 Remarks	번호 No.	부품 번호 Part No.	품 명 Description	수량 Q'ty	비 고 Remarks
-	H02-1134	아우트리거 조종 밸브 OUTRIGGER CONTROL VALVE	1	TX50-8					
1	1024005030	블록 커버 앤드 BLOCK COVER END	1						
2	H02-1146	블록 결합체 인넷 BLOCK ASS'Y INLET	1						
3	3019500030	메인 릴리프 밸브 VALVE, MAIN RELIEF	1						
4	H02-1147	블록 결합체 BLOCK ASS'Y WORK	8						
5	H02-1148	스풀 결합체 SPOOL ASS'Y WORK	8						

SPARE PARTS LIST



붐 시스템 BOOM SYSTEM

HIAB190T-6 6 : 0
2013. 01.

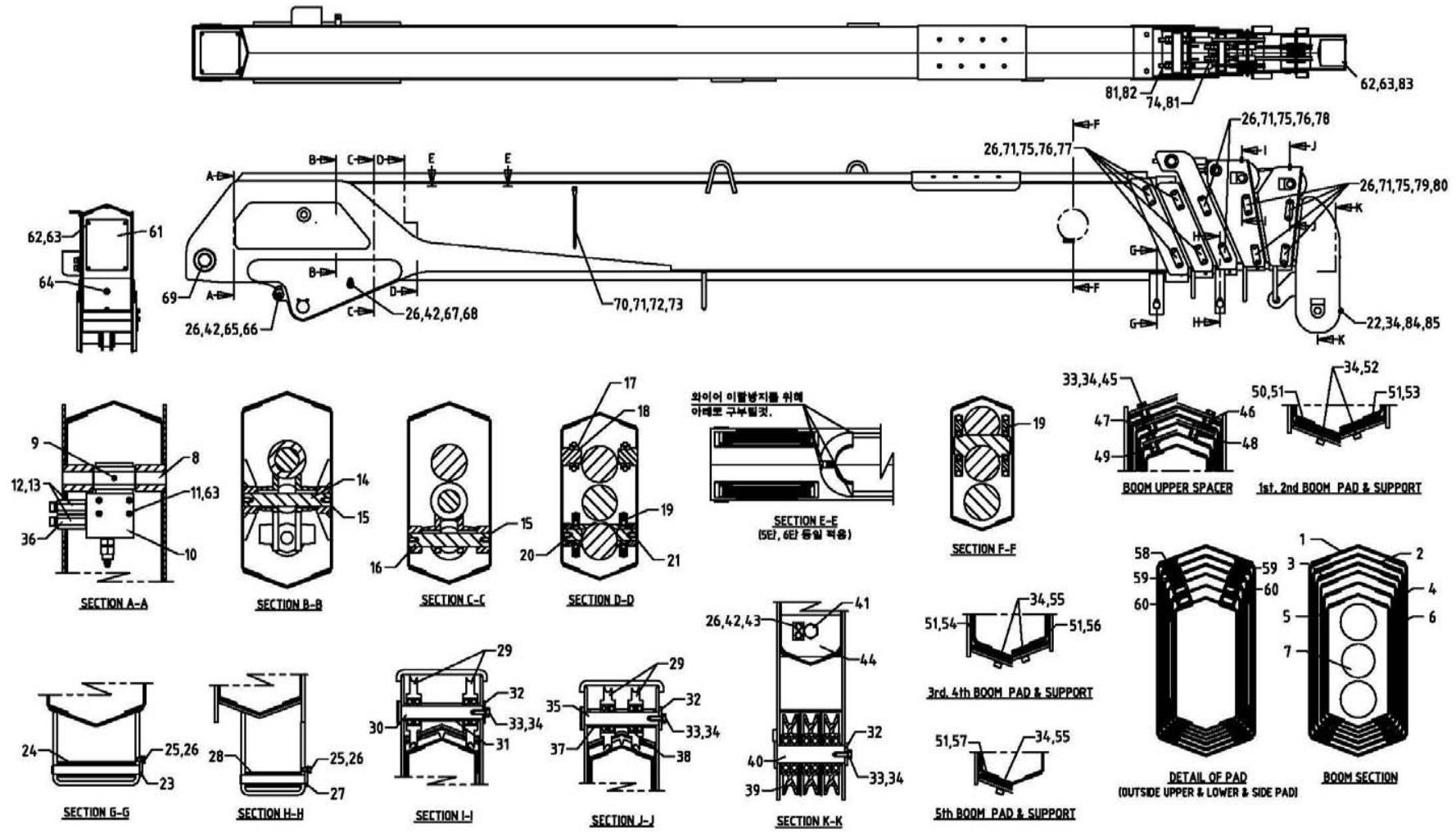

SPARE PARTS LIST



붐 시스템
BOOM SYSTEM

HIAB190T-6 6 : 0
2013. 01.

번호 No.	부품 번호 Part No.	품명 Description	수량 Q'ty	비고 Remarks	번호 No.	부품 번호 Part No.	품명 Description	수량 Q'ty	비고 Remarks
-	A01-3540	붐 시스템 BOOM SYSTEM	1		10	H02-0201	카운터 발런스 밸브 (싱글) VALVE, COUNTER BALANCE (SINGLE)	1	
1	A02-3618	1단 붐 결합체 1st BOOM ASS'Y	1		11	2615617	육각 구멍볼이 볼트 BOLT, HEX. SOCKET HEAD	4	BB6×75
2	A02-3622	2단 붐 결합체 2nd BOOM ASS'Y	1		12	BOO-5051	롱 니플 NIPPLE, LONG	2	PF1/2(O)×PF1/2(C)
3	A02-3623	3단 붐 결합체 3rd BOOM ASS'Y	1		13	6010212	오링 O-RING	6	1B P18
4	A02-3625	4단 붐 결합체 4th BOOM ASS'Y	1		14	BOO-0005	축 SHAFT	1	Φ30×205L
5	A02-3626	5단 붐 결합체 5th BOOM ASS'Y	1		15	4525281	멈춤 링 RING, RETAINING	4	RB30
6	A02-3629	6단 붐 결합체 6th BOOM ASS'Y	1		16	BOO-0006	축 SHAFT	1	Φ30×186L
7	H01-5866	신축 실린더 결합체 EXTENSION CYLINDER ASS'Y	1		17	S01-4537	와이어 로프 ROPE, WIRE	1	Φ10×21210L
8	BOO-6002	축 SHAFT	1	Φ30×230L	18	4510291	멈춤 링 RING, RETAINING	2	RC30
9	2340796	멈춤 나사 SCREW, SET (STICK END)	1	BM10×16	19	A05-3625	쉬브 결합체 SHEAVE ASS'Y	4	

SPARE PARTS LIST



붐 시스템 BOOM SYSTEM

HIAB190T-6 6 : 0
2013. 01.

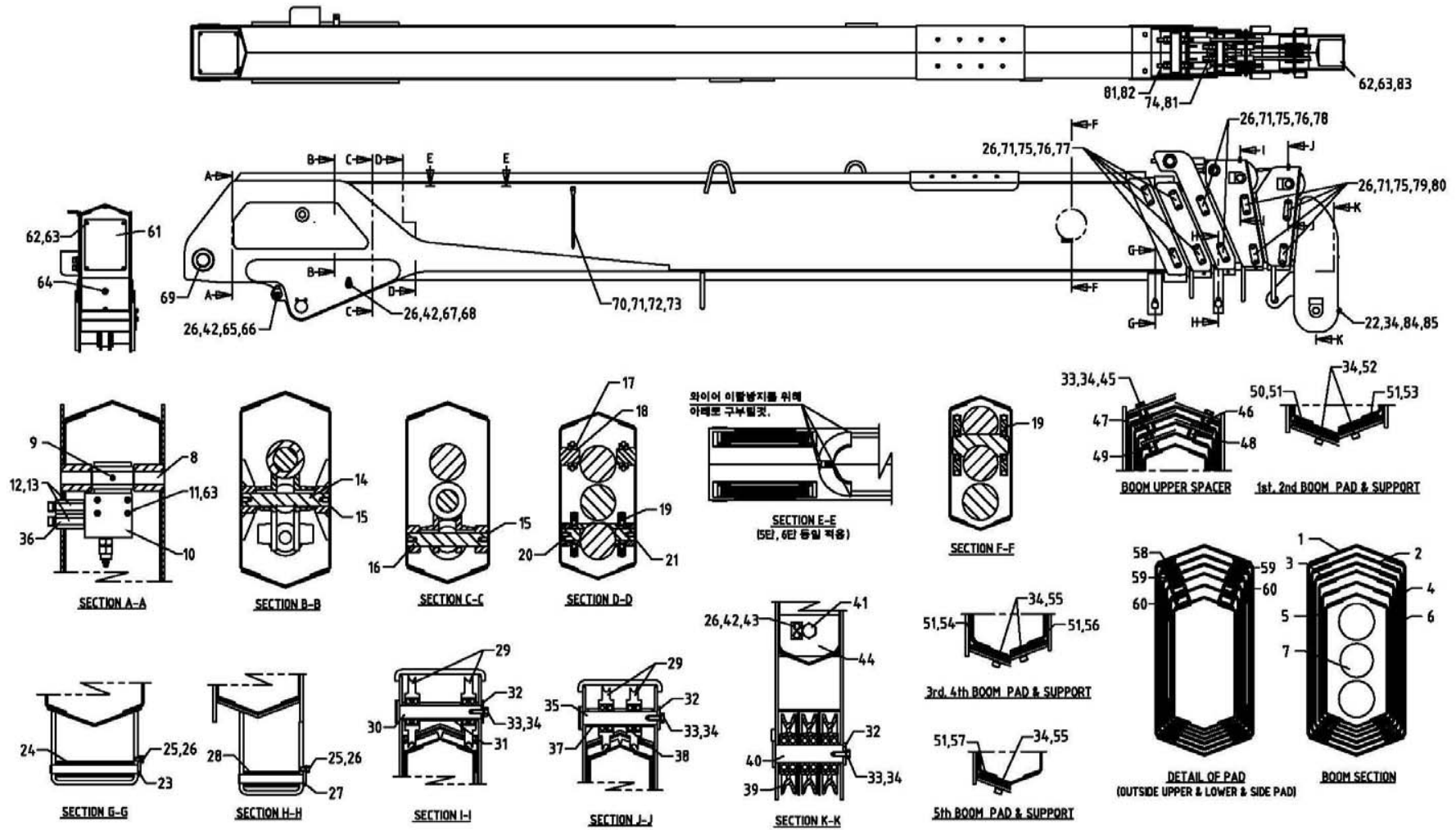

SPARE PARTS LIST



붐 시스템
BOOM SYSTEM

HIAB190T-6 6 : 0
2013. 01.

번호 No.	부품 번호 Part No.	품 명 Description	수량 Q'ty	비 고 Remarks	번호 No.	부품 번호 Part No.	품 명 Description	수량 Q'ty	비 고 Remarks
20	BOO-0007	핀 PIN	2	Φ25×42L	30	BOO-0023	축 SHAFT	1	Φ30×189L
21	4525251	멈춤 링 RING, RETAINING	2	RB25	31	BOO-0026	스페이서 SPACER	1	Φ40×92L
22	3112106	육각 너트 NUT, HEX.	2	NA10	32	N01-0543	플레이트 PLATE	3	t=6
23	BOO-0014	축 SHAFT	1	Φ20×202L	33	2111187	육각 볼트 BOLT, HEX. HEAD	13	BA10×20
24	BOO-0016	롤러 결합체 ROLLER ASS'Y	1	Φ34×180L	34	3612101	스프링 와셔 WASHER, SPRING	25	WS10
25	2110866	육각 볼트 BOLT, HEX. HEAD	19	BA8×16	35	BOO-0027	축 SHAFT	1	Φ30×173L
26	3612081	스프링 와셔 WASHER, SPRING	47	WS8	36	S01-1579	스위블 엘보 ELBOW, SWIVEL	1	2-PF1/2
27	BOO-0018	축 SHAFT	1	Φ20×165L	37	BOO-0030	스페이서 SPACER	2	Φ40×29L
28	BOO-0019	롤러 결합체 ROLLER ASS'Y	1	Φ34×142L	38	BOO-0031	스페이서 SPACER	1	Φ40×22L
29	A05-2553	쉬브 결합체 SHEAVE ASS'Y	4		39	A05-2548	쉬브 결합체 SHEAVE ASS'Y	3	

SPARE PARTS LIST



붐 시스템 BOOM SYSTEM

HIAB190T-6 6 : 0
2013. 01.

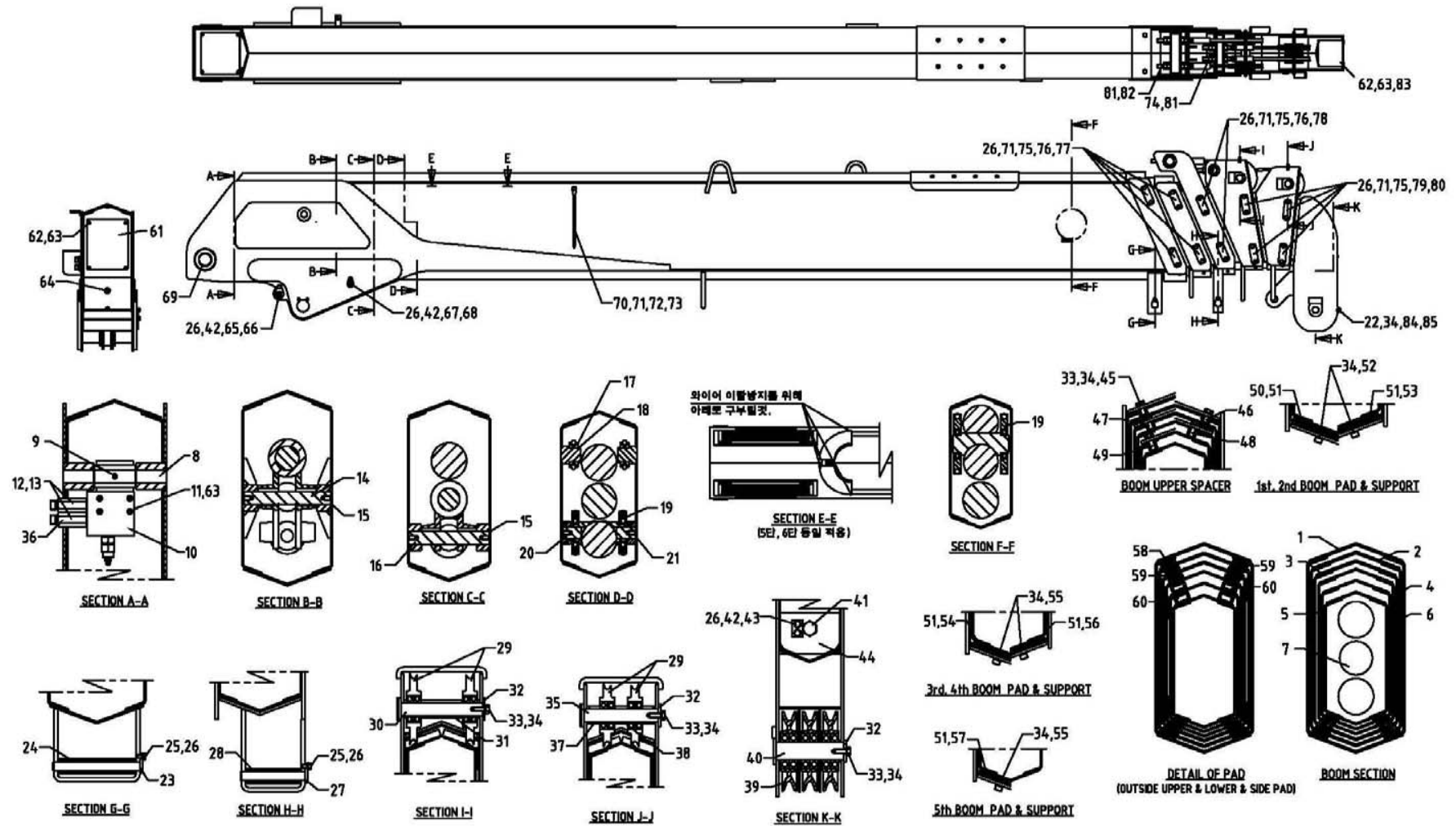

SPARE PARTS LIST



붐 시스템
BOOM SYSTEM

HIAB190T-6 6 : 0
2013. 01.

번호 No.	부품 번호 Part No.	품명 Description	수량 Q`ty	비고 Remarks	번호 No.	부품 번호 Part No.	품명 Description	수량 Q`ty	비고 Remarks
40	BOO-0035	축 SHAFT	1	Φ40×157L	50	BOO-5052	패드 가이드 GUIDE, PAD	1	
41	BOO-0073	육각 볼트 BOLT, HEX. HEAD	1	M20×220	51	S01-3122	슬라이드 패드 PAD, SLIDE	10	40×210×6t
42	2110886	육각 볼트 BOLT, HEX. HEAD	28	BA8×20	52	2611186	육각 구멍볼이 볼트 BOLT, HEX. SOCKET HEAD	4	BB10×20
43	N01-0535	플레이트 PLATE	1	25×40×6t	53	BOO-5056	패드 가이드 GUIDE, PAD	1	
44	BOO-0032	와이어 가이드 GUIDE, WIRE	1		54	BOO-5059	패드 가이드 GUIDE, PAD	1	
45	B00-0042	육각 너트 NUT, HEX.	2	t=19.5	55	2611176	육각 구멍볼이 볼트 BOLT, HEX. SOCKET HEAD	6	BB10×18
46	BOO-0043	육각 너트 NUT, HEX.	2	t=17.5	56	BOO-5062	패드 가이드 GUIDE, PAD	1	
47	BOO-0044	육각 너트 NUT, HEX.	2	t=15.5	57	BOO-5065	패드 가이드 GUIDE, PAD	1	
48	BOO-0045	육각 너트 NUT, HEX.	2	t=24	58	BOO-8002	슬라이드 패드 PAD, SLIDE	2	35×220×10t
49	BOO-0046	육각 너트 NUT, HEX.	2	t=23	59	BOO-5037	슬라이드 패드 PAD, SLIDE	4	35×220×9t

SPARE PARTS LIST



붐 시스템 BOOM SYSTEM

HIAB190T-6 6 : 0
2013. 01.

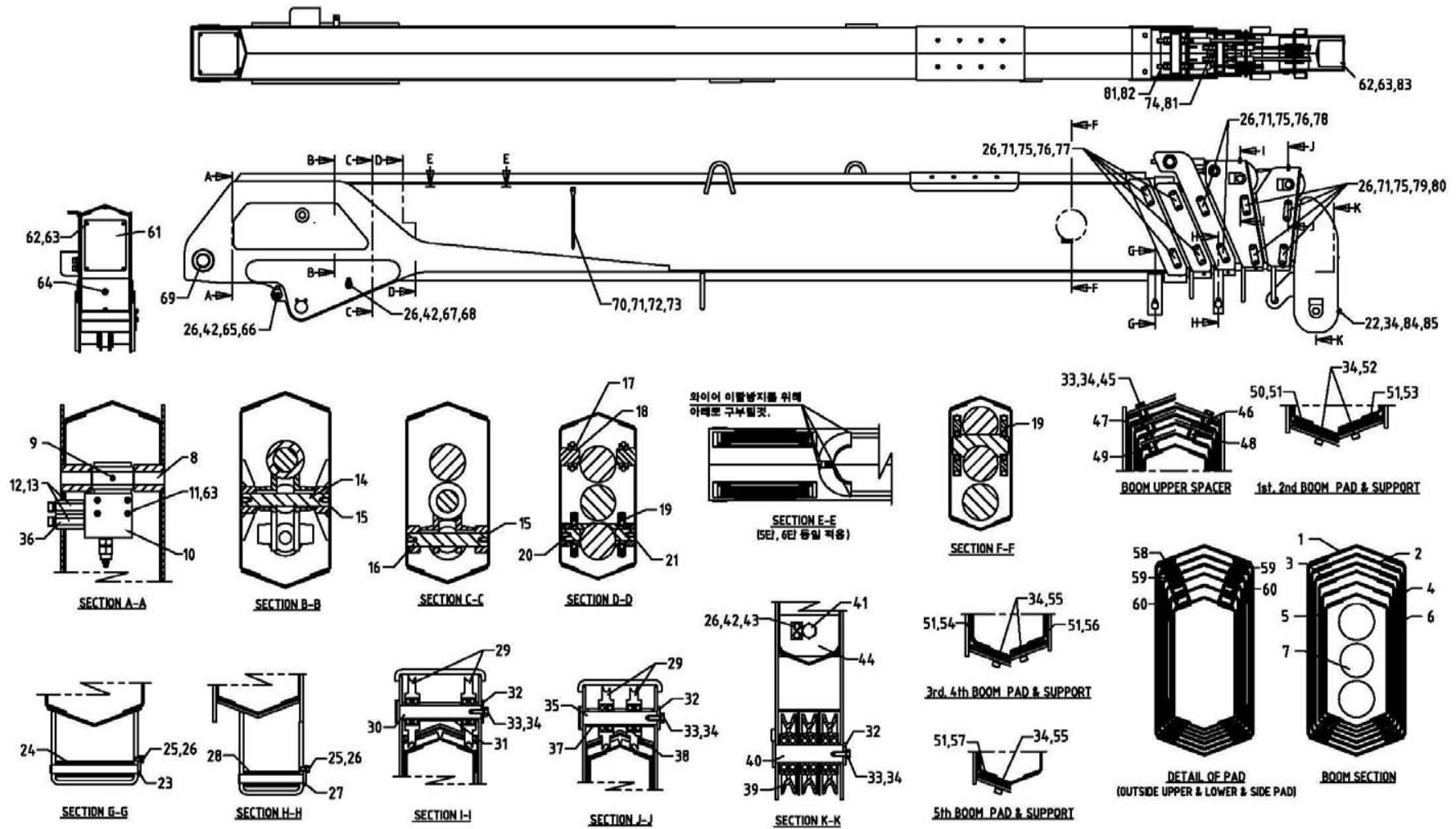

SPARE PARTS LIST



붐 시스템
BOOM SYSTEM

HIAB190T-6 6 : 0
2013. 01.

번호 No.	부품 번호 Part No.	품 명 Description	수량 Q'ty	비 고 Remarks	번호 No.	부품 번호 Part No.	품 명 Description	수량 Q'ty	비 고 Remarks
60	BOO-5041	슬라이드 패드 PAD, SLIDE	4	35×220×18t	70	N01-0590	각도 지시계 INDICATOR, ROD	2	t=4.5
61	BOO-0062	플레이트 PLATE	1	t=2.3	71	2110906	육각 볼트 BOLT, HEX. HEAD	2	BA8×25
62	2110446	육각 볼트 BOLT, HEX. HEAD	8	BA6×16	72	3112086	육각 너트 NUT, HEX.	2	NA8
63	3612061	스프링 와셔 WASHER, SPRING	12	WS6	73	3511081	평 와셔 WASHER, PLAIN	4	WP8
64	4610702	그리스 니플 NIPPLE, GREASE	1	A-PT1/8	74	S01-5086	와이어 로프 ROPE, WIRE	1	Φ10×7660L
65	S01-2246	축 SHAFT	1	Φ30×245L	75	N01-3491	플레이트 PLATE	20	32×90×12t
66	A05-1796	롤러 결합체 ROLLER ASS'Y	1	Φ48.6×228L	76	S01-3515	슬라이드 패드 PAD, SIDE	12	19×49×17t
67	BOO-8004	축 SHAFT	1	Φ20×275L	77	BOO-2053	심 SHIM	8	t=1.0
68	BOO-8005	롤러 결합체 ROLLER ASS'Y	1	Φ34×228L	78	BOO-0058	심 SHIM	4	t=2.5
69	4321291	DU 부싱 BUSHING, DU	2	MB6060DU	79	S01-3121	사이드 패드 PAD, SIDE	8	19×49×14t

SPARE PARTS LIST



붐 시스템 BOOM SYSTEM

HIAB190T-6 6 : 0
2013. 01.

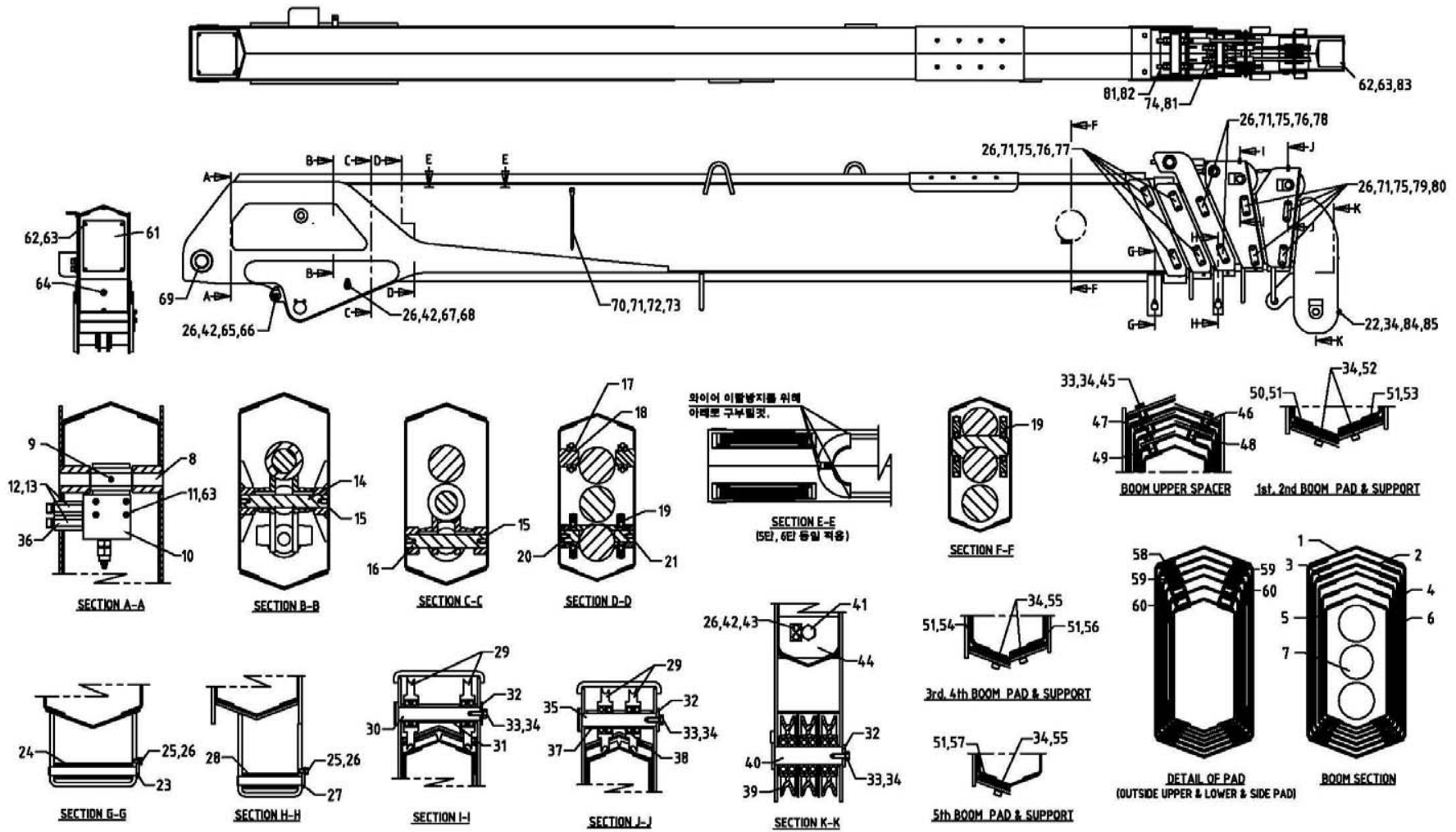

SPARE PARTS LIST



붐 시스템
BOOM SYSTEM

HIAB190T-6 6 : 0
2013. 01.

번호 No.	부품 번호 Part No.	품 명 Description	수량 Q`ty	비 고 Remarks	번호 No.	부품 번호 Part No.	품 명 Description	수량 Q`ty	비 고 Remarks
80	BOO-0059	삼 SHIM	8	t=2.0					
81	3112181	육각 너트 NUT, HEX.	12	NA18					
82	S01-2993	와이어 로프 ROPE, WIRE	1	Φ10×7600L					
83	BOO-2039	커버 COVER	1	t=2.3					
84	BOO-5048	볼트 BOLT	1	M10					
85	BOO-5049	파이프 PIPE	1	t=2.3					
86	BOO-5050	육각 너트 NUT, HEX.	2	NA10					

SPARE PARTS LIST



신축 실린더 결합체
EXTENSION CYLINDER ASS'Y

HIAB190T-6 7:0
2013.01.

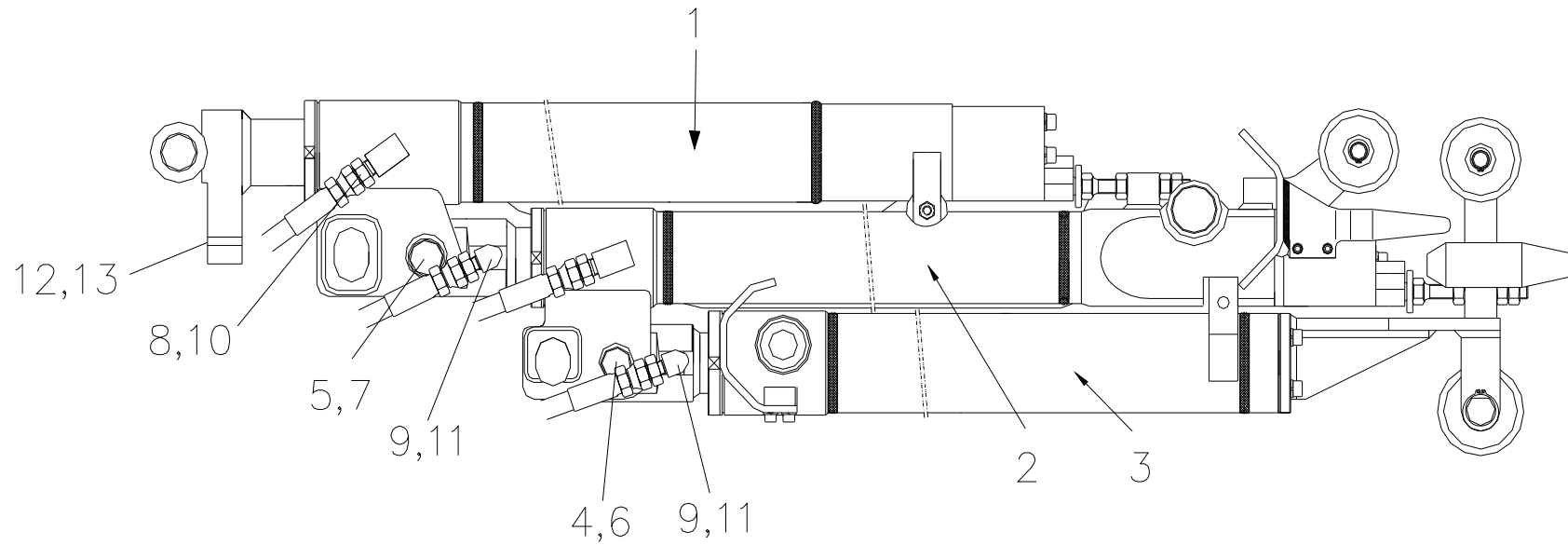

SPARE PARTS LIST



신축 실린더 결합체
EXTENSION CYLINDER ASS'Y

HIAB190T-6 7:0
2013. 01.

번호 No.	부품 번호 Part No.	품명 Description	수량 Q'ty	비고 Remarks	번호 No.	부품 번호 Part No.	품명 Description	수량 Q'ty	비고 Remarks
-	H01-5866	신축 실린더 EXTENSION CYLINDER	1	HN98T0000	10	9211092	아답터 ADAPTER-A	4	ZPC3010-6-6
1	HN03T1A00-02	1단 신축 실린더 1st EXTENSION CYLINDER	1		11		아답터 ADAPTER-B	4	ZPC3020-6-6
2	HN98T2000	2단 신축 실린더 2nd EXTENSION CYLINDER	1		12		더스트 커버 DUST COVER	1	67×85×3T
3	HN98T3000	3단 신축 실린더 3rd EXTENSION CYLINDER	1		13		소켓 볼트 SOCKET BOLT	2	M6×P1.0×10L
4	SS25T0010	핀 PIN-A	1	Φ25×73L	14		케이블 TI CABLE	2	
5	SS33T0010	핀 PIN-B	1	Φ30×73L					
6	4510251	스냅링 SNAP RING	2	R25					
7	4510291	스냅링 SNAP RING	2	R30					
8	7116563	유압 호스 HOSE, HYDRAULIC	2	PF3/8×PF3/8-390L					
9	7116573	유압 호스 HOSE, HYDRAULIC	2	PF3/8×PF38-420L					

SPARE PARTS LIST



1단 신축 실린더 결합체
1st EXTENSION CYLINDER ASS'Y

HIAB190T-6 8:0
2013. 01.

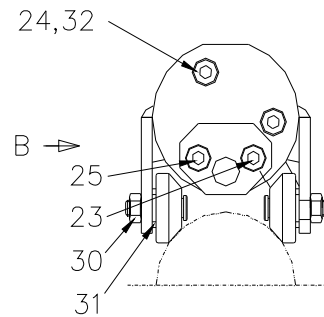
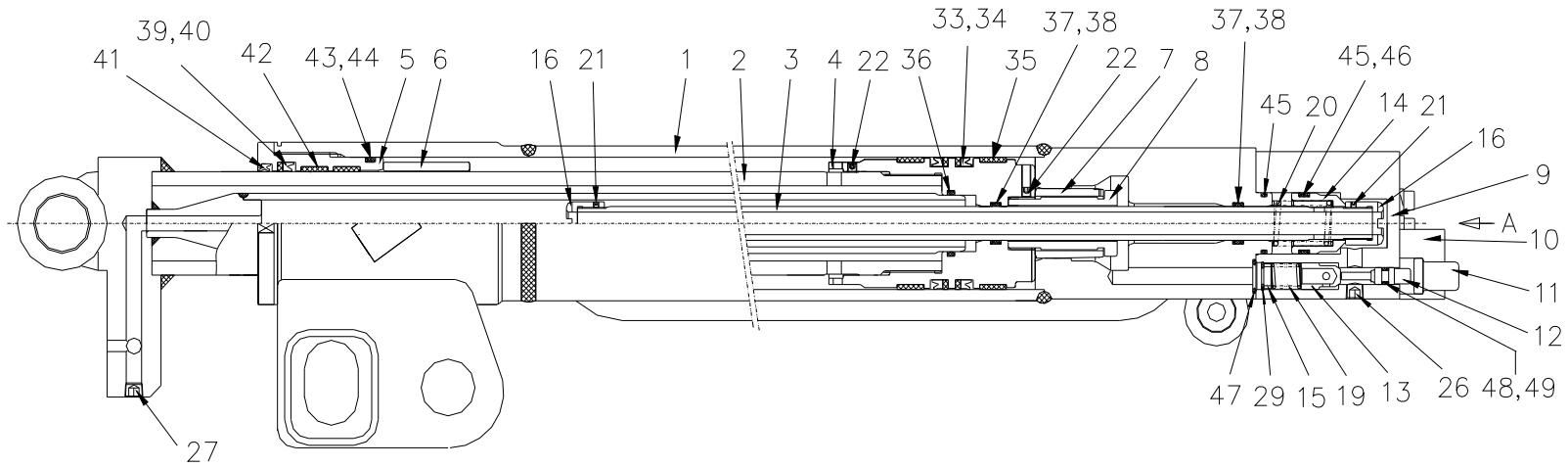

VIEW A

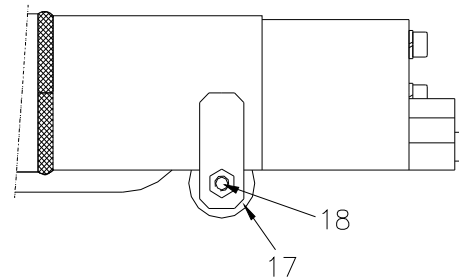

VIEW B

SPARE PARTS LIST



1단 신축 실린더 결합체
1st EXTENSION CYLINDER ASS'Y

HIAB190T-6 8 : 0
2013. 01.

번호 No.	부품 번호 Part No.	품명 Description	수량 Q'ty	비고 Remarks	번호 No.	부품 번호 Part No.	품명 Description	수량 Q'ty	비고 Remarks
-	H01-1429-1	1단 신축 실린더 결합체 1st EXTENSION CYLINDER ASS'Y	1		10	SS33T10A1	브라켓-A BRACKET-A	1	
1	HN03T1010	튜브 결합체 TUBE ASS'Y	1		11	SS33T10A2	스풀 가이드 SPOOL GUIDE	1	
2	HN03T1020	로드 결합체 ROD ASS'Y	1		12	SS33T10A3	스풀 SPOOL	1	
3	HN03T1030	리트랙터 RETRACTOR	1		13	SS33T10A4	밸브-A VALVE-A	1	
4	SH15T1040	피스톤 PISTON	1		14	SS33T10A5	밸브-B VALVE-B	1	
5	SS33T1050	로드 커버 ROD COVER	1		15	SS33T10A6	와셔-A WASHER-A	1	
6	KL08T1040	스페이서 SPACER	1		16	HN01T1060	멈춤 너트 STOP NUT	2	
7	SS33T1070	쿠션 링 CUSHION RING	1		17	KL08T10P1	롤러 패드 ROLLER PAD	2	Φ36×14W
8	SS33T1080	쿠션 가이드 CUSHION GUIDE	1		18	KL08T1070	롤러 축 ROLLER SHAFT	2	Φ13×33.5L
9	SH16T1090	밸브 바디 VALVE BODY	1		19	SS33T10S1	스프링-A SPRING-A	1	

SPARE PARTS LIST



1단 신축 실린더 결합체
1st EXTENSION CYLINDER ASS'Y

HIAB190T-6 8 : 0
2013. 01.

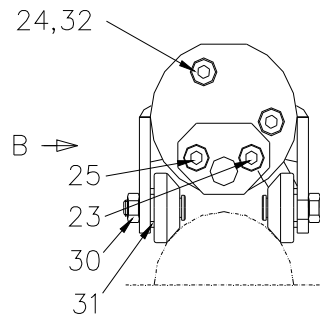
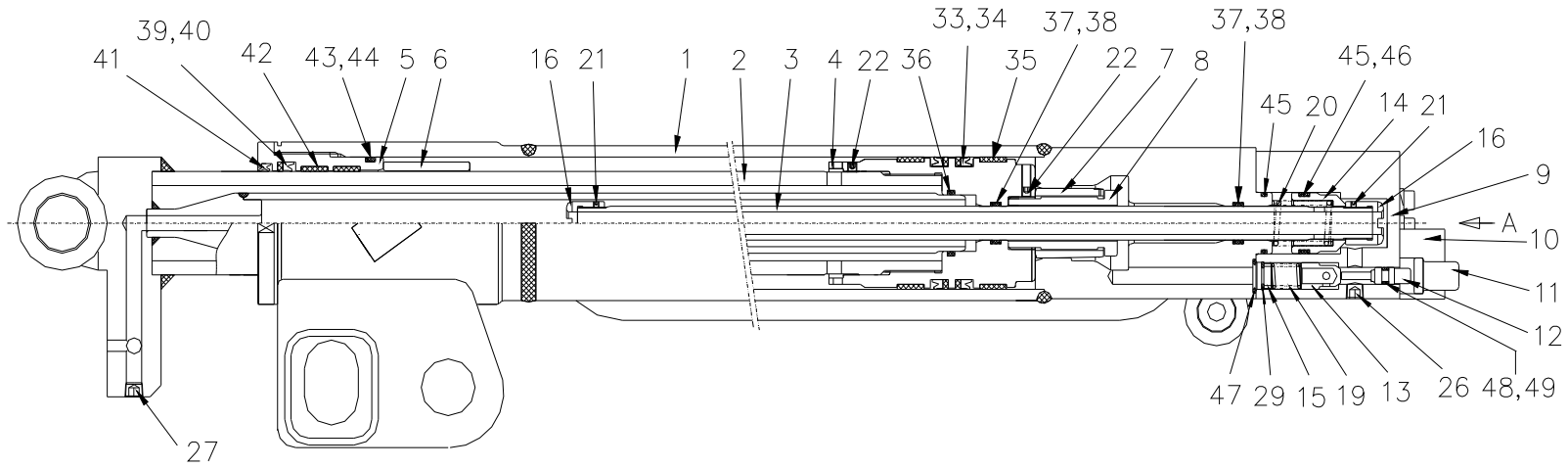

VIEW A

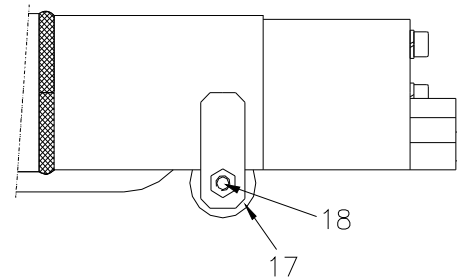

VIEW B

SPARE PARTS LIST



1단 신축 실린더 결합체
1st EXTENSION CYLINDER ASS'Y

HIAB190T-6 8 : 0
2013. 01.

번호 No.	부품 번호 Part No.	품명 Description	수량 Q'ty	비고 Remarks	번호 No.	부품 번호 Part No.	품명 Description	수량 Q'ty	비고 Remarks
20	SS33T10S2	스프링-B SPRING-B	1		30	3112086	육각 너트 NUT, HEX.	2	NA8
21	2350336	멈춤 나사 SCREW, SET	2	BV5×5	31	3511101	평 와셔 WASHER, PLAIN	2	WP10
22	2350446	멈춤 나사 SCREW, SET	2	BV6×6	32	3612081	스프링 와셔 WASHER, SPRING	2	WS8
23	2610937	육각 구멍볼이 볼트 BOLT, HEX. SOCKET HEAD	1	BB8×35	33	6510161	피스톤 패킹 PACKING, PISTON	2	OSI 70×60×6
24	2611067	육각 구멍볼이 볼트 BOLT, HEX. SOCKET HEAD	2	BB8×100	34	6037141	백업 링 RING, BACK UP	2	60×70×3
25	2611087	육각 구멍볼이 볼트 BOLT, HEX. SOCKET HEAD	1	BB8×110	35	S01-0641	웨어 링 RING, WEAR	2	65×70×15
26	S01-0493	플러그 PLUG	2	PT1/8×7L	36	6012262	오링 O-RING	1	1B G30
27	S01-0398	플러그 PLUG	3	PT1/4×9L	37	6010212	오링 O-RING	2	1B P18
28	BOO-0002-1-23	베어링 BEARING	2	#6900ZZ	38	6034191	백업 링 RING, BACK UP	4	18×22×1.25
29	4525151	멈춤 나사 SCREW, SET	1	RB14	39	6513691	로드 패킹 PACKING, ROD	1	ISI 55×65×6

SPARE PARTS LIST



1단 신축 실린더 결합체
1st EXTENSION CYLINDER ASS'Y

HIAB190T-6 8:0
2013. 01.

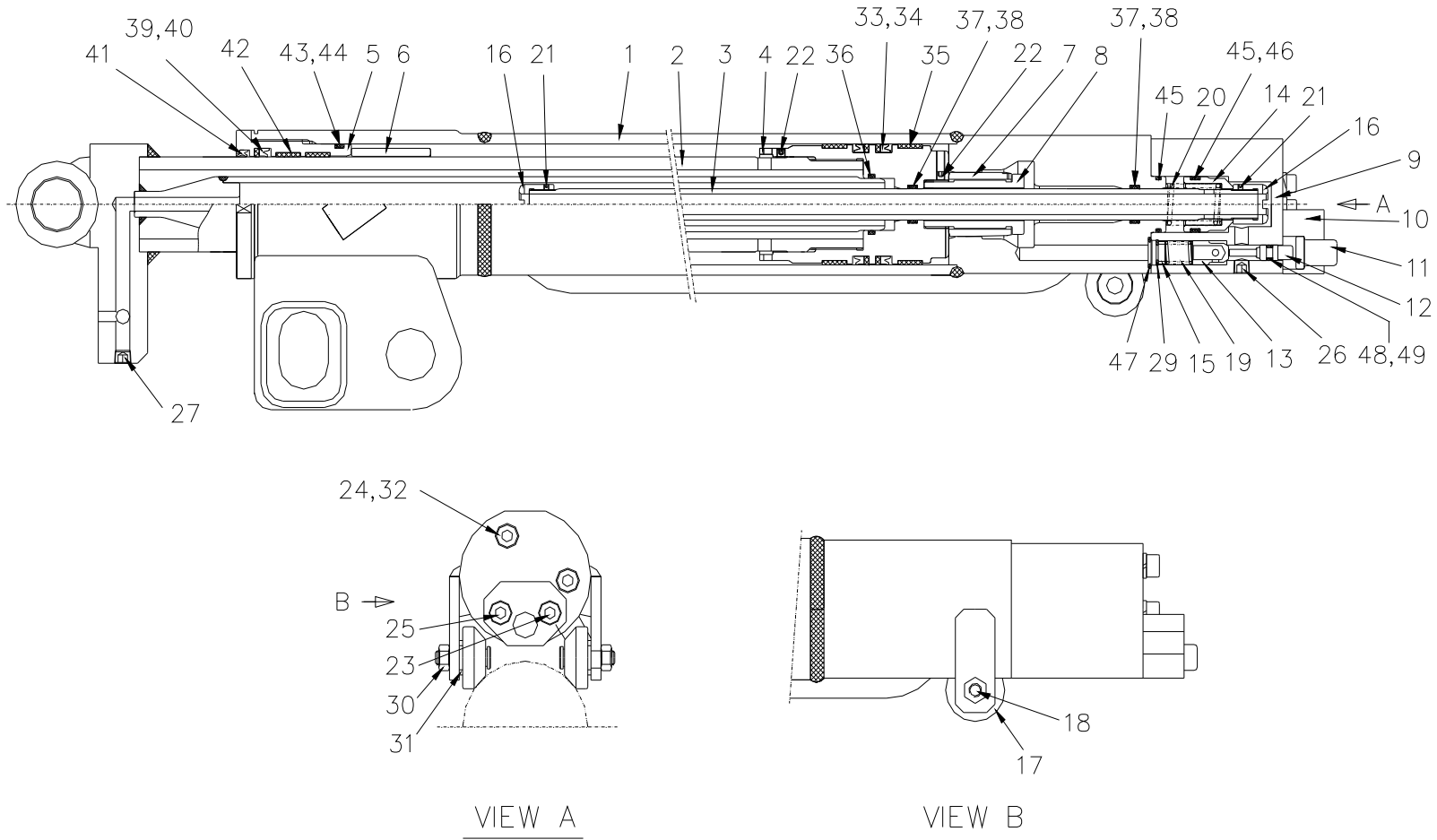

SPARE PARTS LIST



1단 신축 실린더 결합체
1st EXTENSION CYLINDER ASS'Y

HIAB190T-6 8 : 0
2013. 01.

번호 No.	부품 번호 Part No.	품 명 Description	수량 Q'ty	비 고 Remarks	번호 No.	부품 번호 Part No.	품 명 Description	수량 Q'ty	비 고 Remarks
40	6037071	백업 링 RING, BACK UP	1	55×65×3					
41	6115651	더스트 시일 SEAL, DUST	1	KDD 55×63×5×6.5	-	S01-0917	시일 세트 SEAL SET	1	
42	S01-0872	웨어 링 RING, WEAR	2	55×60×3					
43	6012332	오 링 O-RING	1	1B G65					
44	6035281	백업 링 RING, BACK UP	1	65×7×1.25					
45	S01-0907	오 링 O-RING	2	JASO#2028					
46	S01-0908	백업 링 RING, BACK UP	2	28×33×1.25					
47	6010172	오 링 O-RING	2	1B P14					
48	S01-0906	오 링 O-RING	1	4D P6					
49	6032061	백업 링 RING, BACK UP	1	6×9×1.25					

SPARE PARTS LIST



2단 신축 실린더
2nd EXTENSION CYLINDER

HIAB190T-6 9:0
2013. 01.

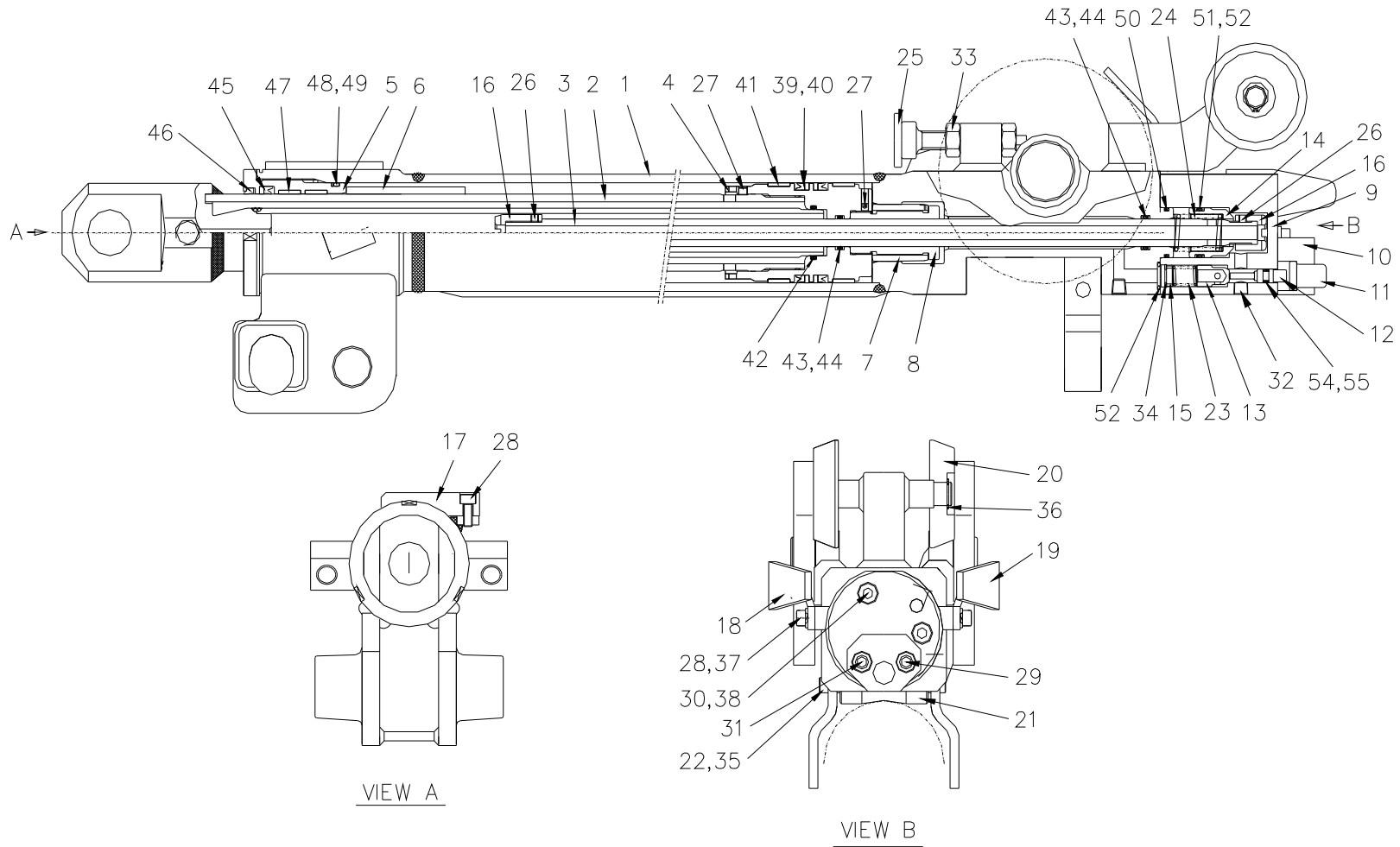

SPARE PARTS LIST



2단 신축 실린더
2nd EXTENSION CYLINDER

HIAB190T-6 9 : 0
2013. 01.

번호 No.	부품 번호 Part No.	품명 Description	수량 Q'ty	비고 Remarks	번호 No.	부품 번호 Part No.	품명 Description	수량 Q'ty	비고 Remarks
-	H01-5867	2단 신축 실린더 2nd EXTENSION CYLINDER	1	HN98T2000	10	SS33T10A1	브라켓 BRACKET - A	1	
1	HN98T2010	튜브 결합체 TUBE ASSY	1		11	SS33T10A2	스풀 가이드 SPOOL GUIDE	1	
2	HN03T2020	로드 결합체 ROD ASSY	1		12	SS33T10A3	스풀 SPOOL	1	
3	HN03T2A30	리트랙터 RETRACTOR	1		13	SS33T10A4	밸브 VALVE - A	1	
4	SH18T1040	피스톤 PISTON	1		14	SS33T10A5	밸브 VALVE - B	1	
5	SH46T2040	로드 커버 ROD COVER	1		15	SS33T10A6	와셔 WASHER - A	1	
6	KL08T2040	스페이서 SPACER	1		16	HN01T1060	멈춤 너트 STOP NUT	2	
7	SS33T2070	쿠션 링 CUSHION RING	1		17	KL08T2070	패드 PAD	1	
8	SS33T1080	쿠션 가이드 CUSHION GUIDE	1		18	HN98T2060	브라켓 결합체 - R BRACKET ASS'Y - R	1	
9	SS33T1090	밸브 바디 VALVE BODY	1		19	HN98T2060	브라켓 결합체 - L BRACKET ASS'Y - L	1	

SPARE PARTS LIST



2단 신축 실린더
2nd EXTENSION CYLINDER

HIAB190T-6 9:0
2013. 01.

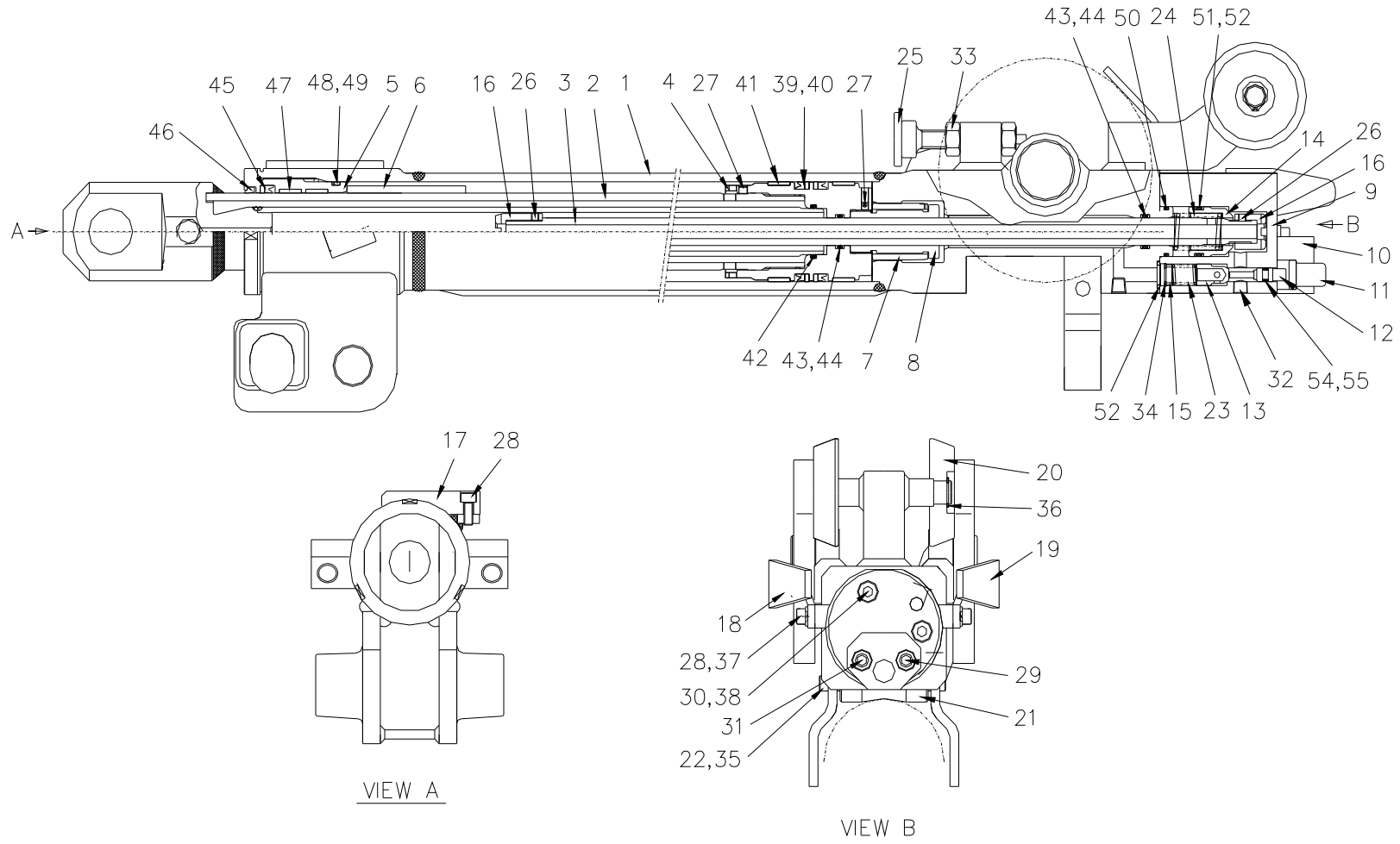

SPARE PARTS LIST



2단 신축 실린더
2nd EXTENSION CYLINDER

HIAB190T-6 9 : 0
2013. 01.

번호 No.	부품 번호 Part No.	품명 Description	수량 Q'ty	비고 Remarks	번호 No.	부품 번호 Part No.	품명 Description	수량 Q'ty	비고 Remarks
20	HN21T2A60	가이드 롤러 GUIDE ROLLER	2		30		소켓 볼트 SOCKET BOLT	2	M8×P1.25×100L *
21	KL08T20P2	롤러 패드 ROLLER PAD	1		31		소켓 볼트 SOCKET BOLT	1	M8×P1.25×110L *
22	KL05ET190	롤러 샤프트 ROLLER SHAFT	1		32		플러그 PLUG	2	PT1/8×7L *
23	SS33T10S1	스프링 SPRING - A	1		33		너트 NUT	3	M12×P1.75×10H *
24	SS33T10S2	스프링 SPRING - B	1		34		스냅 링 SNAP RING	1	Φ14 *
25	SS33T20B1-01	체크 볼트 CHECK BOLT	1	M12×P1.75×85 *	35		분할 핀 PIN, SPLIT	1	Φ3.2×25L *
26		멈춤 나사 SCREW, SET	2	M3×P0.5×3L *	36		스냅 링 SNAP RING	2	Φ15 *
27		멈춤 나사 SCREW, SET	2	M6×P1.0×6L *	37		스프링 와셔 WASHER, SPRING	4	M5 *
28		소켓 볼트 SOCKET BOLT	6	M6×P1.0×15L *	38		스프링 와셔 WASHER, SPRING	2	M8 *
29		소켓 볼트 SOCKET BOLT	1	M8×P1.25×35L *	39		피스톤 패킹 PACKING, PISTON	2	OSI 65 *

SPARE PARTS LIST



2단 신축 실린더
2nd EXTENSION CYLINDER

HIAB190T-6 9:0
2013. 01.

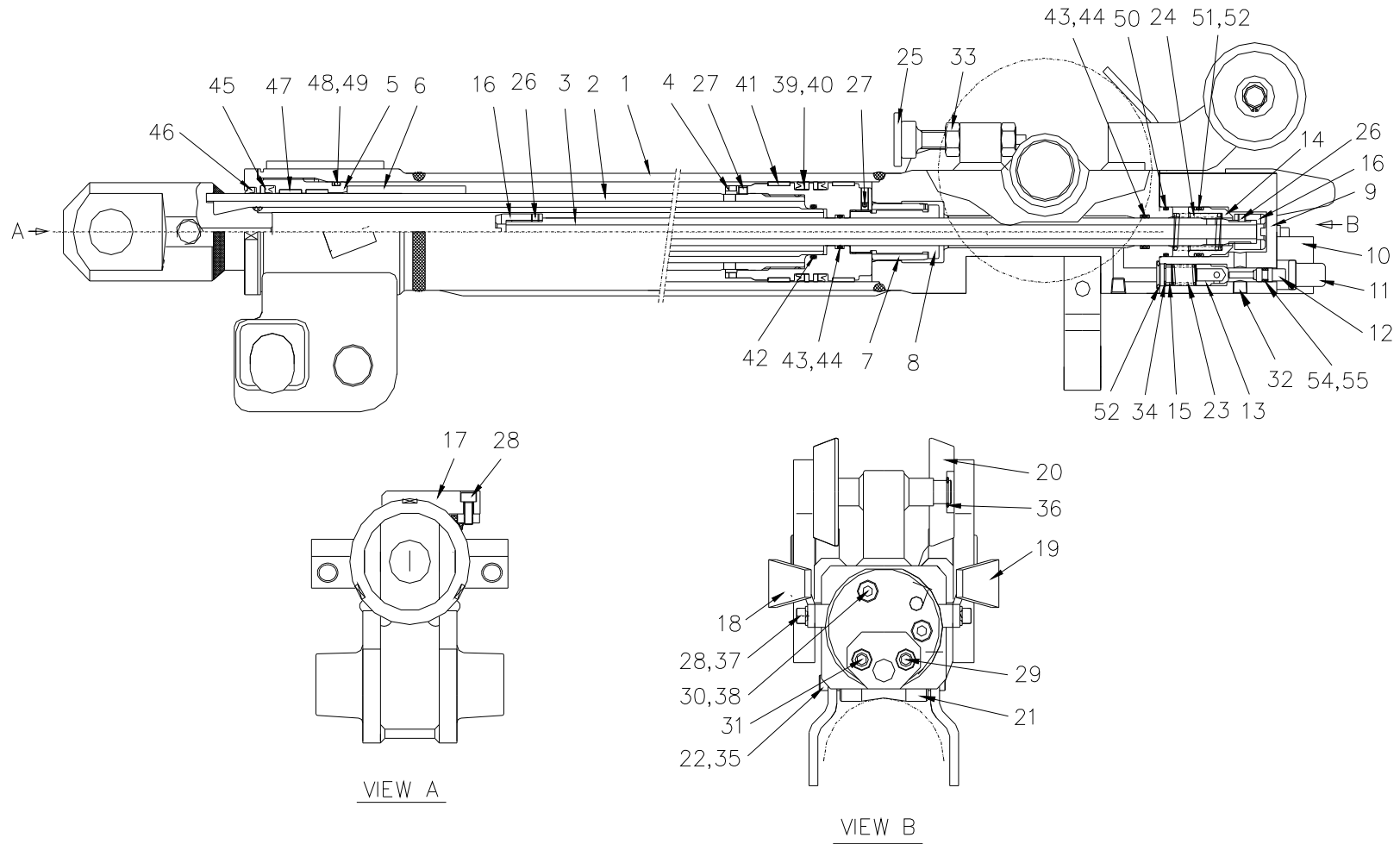

SPARE PARTS LIST



2단 신축 실린더
2nd EXTENSION CYLINDER

HIAB190T-6 9 : 0
2013. 01.

번호 No.	부품 번호 Part No.	품 명 Description	수량 Q'ty	비 고 Remarks	번호 No.	부품 번호 Part No.	품 명 Description	수량 Q'ty	비 고 Remarks
40		백업 링 RING, BACK-UP	2	Φ65×Φ55×t3.0 *	50		O-링 O-RING	2	Φ28×Φ33 *
41		웨어 링 RING, WEAR	2	Φ65×Φ60×15w *	51		백업 링 RING, BACK-UP	2	Φ28×Φ33 *
42		O-링 O-RING	1	1B G30 *	52		O-링 O-RING	2	1B P14 *
43		O-링 O-RING	2	1B P18 *	53		O-링 O-RING	1	1AP 6 *
44		백업 링 RING, BACK-UP	4	(T-3) P12 *	54		백업 링 RING, BACK-UP	1	(T-3) P6 *
45		로드 패킹 PACKING, ROD	1	NI-300 Φ50× Φ60×10W *					
46		더스트 시일 SEAL, DUST	1	KDD 50 *					
47		웨어 링 RING, WEAR	2	Φ50×Φ55×15w *	-	S01-4999	시일 세트 SEAL SET	1	
48		O-링 O-RING	1	1BG 60 *					
49		백업 링 RING, BACK-UP	1	(T-3) G60 *					

SPARE PARTS LIST



3단 신축 실린더
3rd EXTENSION CYLINDER

HIAB190T-6 10:0
2013. 01.

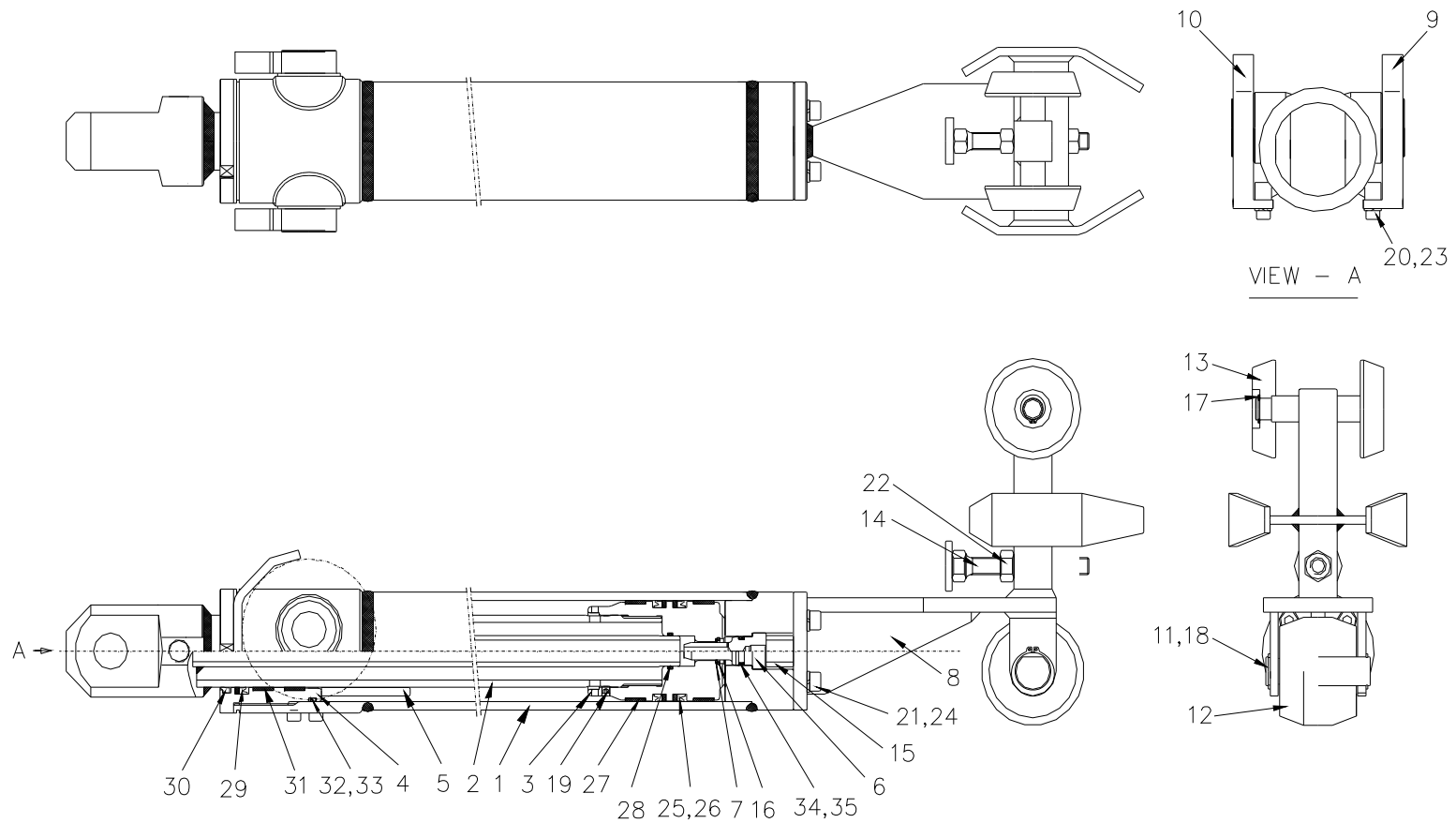

SPARE PARTS LIST



3단 신축 실린더
3rd EXTENSION CYLINDER

HIAB190T-6 10:0
2013. 01.

번호 No.	부품 번호 Part No.	품명 Description	수량 Q'ty	비고 Remarks	번호 No.	부품 번호 Part No.	품명 Description	수량 Q'ty	비고 Remarks
-	H01-5868	3단 신축 실린더 3rd EXTENSION CYLINDER	1	HN98T3000	10	HN98T3080	브라켓 - L BRACKET - L	1	
1	HN98T3010	튜브 결합체 TUBE ASSY	1		11	SH39T2060	롤러 샤프트 SHAFT, ROLLER	1	Φ20×79L
2	HN03T3020	로드 결합체 ROD ASSY	1		12	SH09T2040	가이드 롤러 ROLLER, GUIDE	1	Φ75×56L
3	KL07T3030-10	피스톤 PISTON	1		13	SH17T2040	가이드 롤러 ROLLER, GUIDE	2	Φ70×17L
4	SH46T3040	로드 커버 ROD COVER	1		14	SS33T20B1-01	체크 볼트 BOLT, CHECK	1	
5	SH15T3050	스페이서 SPACER	1		15	SH16T3070	스페이서 - B SPACER - B	1	Φ15.3×Φ21.7×20
6	SS25T2050	쿠션 CUSHION	1		16		멈춤 링 STOP RING	1	AR18 *
7	SS25T2060	쿠션 링 CUSHION RING	1		17		스냅 링 SNAP RING	2	Φ15 *
8	HN03T3A10	브라켓 BRACKET ASS'Y	1		18		스냅 링 SNAP RING	2	Φ20 *
9	HN98T3070	브라켓 -R BRACKET - R	1		19		멈춤 나사 SCREW, SET	1	M5×P1.0×6L *

SPARE PARTS LIST



3단 신축 실린더
3rd EXTENSION CYLINDER

HIAB190T-6 10:0
2013. 01.

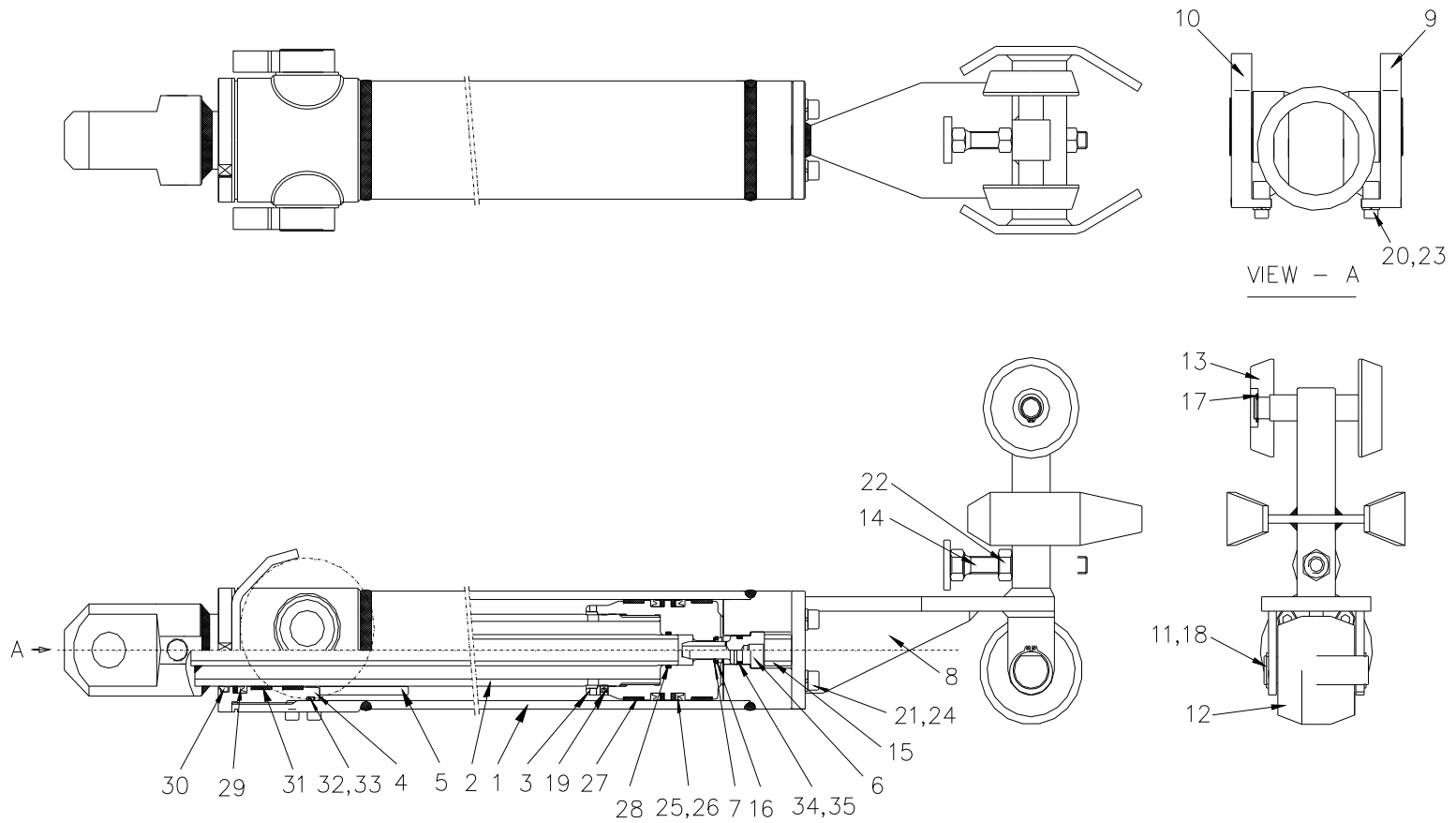

SPARE PARTS LIST



3단 신축 실린더
3rd EXTENSION CYLINDER

HIAB190T-6 10:0
2013. 01.

번호 No.	부품 번호 Part No.	품명 Description	수량 Q'ty	비고 Remarks	번호 No.	부품 번호 Part No.	품명 Description	수량 Q'ty	비고 Remarks
20		소켓 볼트 SOCKET BOLT	4	M6×P1.0×15L *	30		더스트 시일 SEAL, DUST	1	KDD 50 *
21		소켓 볼트 SOCKET BOLT	4	M8×P1.25×30L *	31		웨어 링 RING, WEAR	2	Φ50×Φ55×15w *
22		너트 NUT	3	M12×P1.75×10H *	32		오링 O-RING	1	1B G65 *
23		스프링 와셔 WASHER, SPRING	4	M6 *	33		백업 링 RING, BACK-UP	1	(T-3) G65 *
24		스프링 와셔 WASHER, SPRING	4	M8 *	34		오링 O-RING	1	1B P16 *
25		피스톤 패킹 PACKING, PISTON	2	OSI 70 *	35		백업 링 RING, BACK-UP	1	(T-2) P16 *
26		백업 링 RING, BACK-UP	2	Φ60×Φ70×t3.0 *					
27		웨어 링 RING, WEAR	2	Φ70×Φ65×15w *					
28		오링 O-RING	2	1B P20 *	-	S01-2129	시일 세트 SEAL SET	1	
29		로드 패킹 PACKING, ROD	1	NI-300 50×60×10W *					

SPARE PARTS LIST



카운터 발란스 밸브
VALVE, COUNTER BALANCE (S)

HIAB190T-6 11:0
2013. 01.

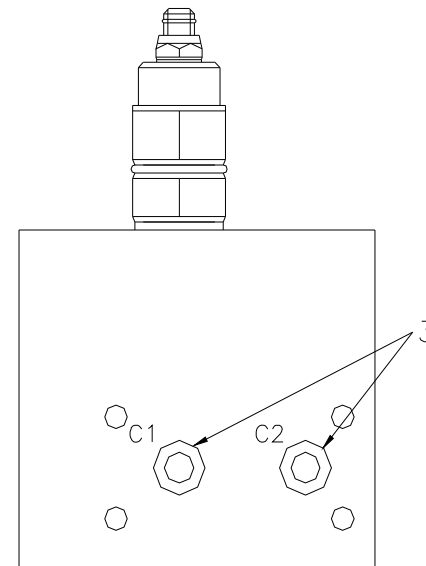
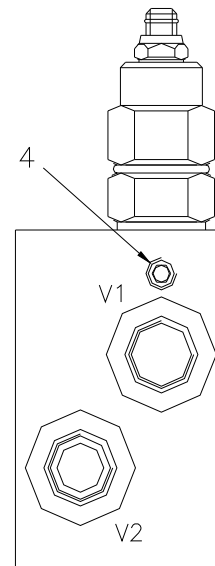
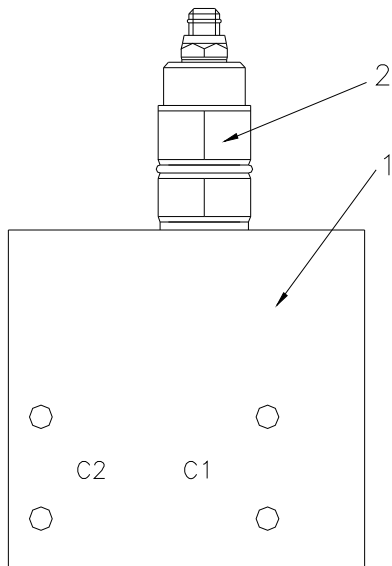
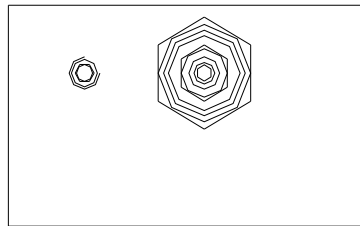

SPARE PARTS LIST



카운터 밸런스 밸브
VALVE, COUNTER BALANCE (S)

HIAB190T-6 11:0
2013. 01.

번호 No.	부품 번호 Part No.	품명 Description	수량 Q'ty	비고 Remarks	번호 No.	부품 번호 Part No.	품명 Description	수량 Q'ty	비고 Remarks
-	H02-0201	카운터 밸런스 밸브 VALVE, COUNTER BALANCE	1	9706-04D-P09					
1	2-A2141-01-0	바디 BODY	1						
2	H02-0198	카운터 밸런스 밸브 COUNTER, BALANCE VALVE	1	9706-04D-P09					
3	6010142	오링 O-RING	2	1B P12					
4	S01-0493	렌치 플러그 PLUG, WRENCH	2	PT1/8					

SPARE PARTS LIST



쉬브 결합체
SHEAVE ASS'Y

HIAB190T-6 12:0
2013. 01.

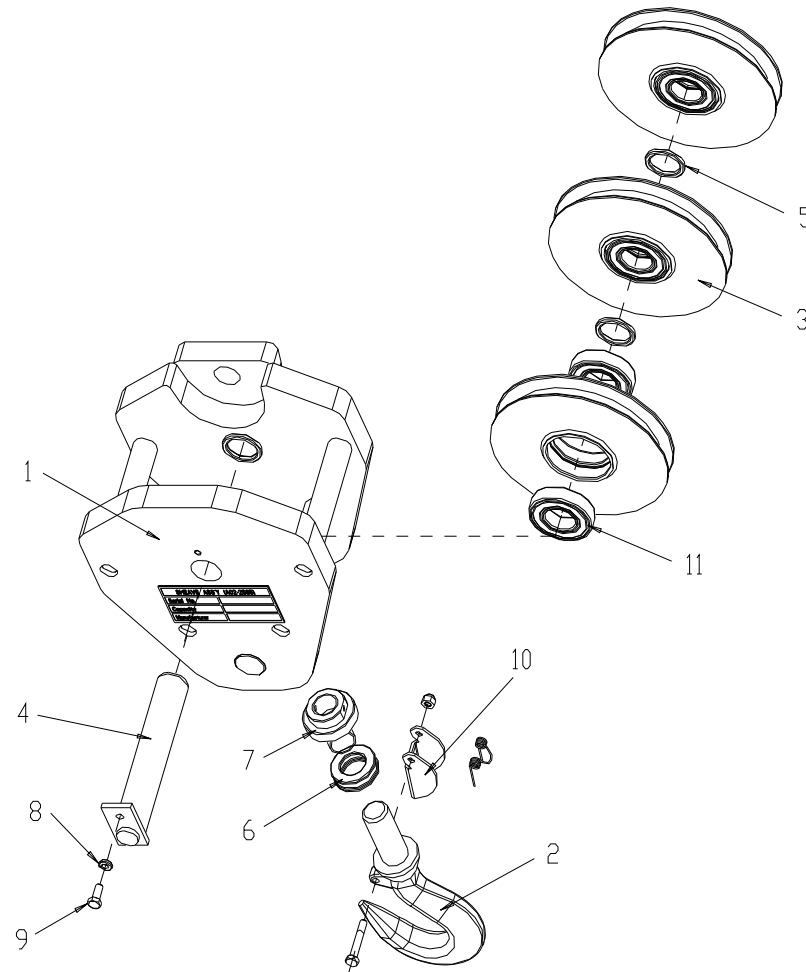

SPARE PARTS LIST



쉬브 결합체
SHEAVE ASS'Y

HIAB190T-6 12:0
2013. 01.

번호 No.	부품 번호 Part No.	품명 Description	수량 Q'ty	비고 Remarks	번호 No.	부품 번호 Part No.	품명 Description	수량 Q'ty	비고 Remarks
-	A02-2565	쉬브 결합체 SHEAVE ASS'Y	1		10	S01-1596	아전 클립 결합체 CLIP ASS'Y, SAFETY	1	
1	HK-1002	바디 BODY	1		11	4112074	베어링 RADIAL BALL BEARING	2	B 6207ZZ
2	M01-1780	후크 HOOK	1						
3	HK-0006	쉬브 SHEAVE	3						
4	HK-0008	축 SHAFT	1						
5	HK-0010	스페이서 SPACER	4						
6	4211060	스러스트 볼 베어링 BEARING, THRUST BALL	1	#51206					
7	HK-0015	록 너트 NUT, LOCK	1	M30×P3.0					
8	3612081	스프링 와셔 WASHER, SPRING	1	WS8					
9	2110887	육각 볼트 BOLT, HEX. HEAD	1	BA8×20					

SPARE PARTS LIST



원치 장치
WINCH SYSTEM

HIAB190T-6 13 : 0
2013. 01.

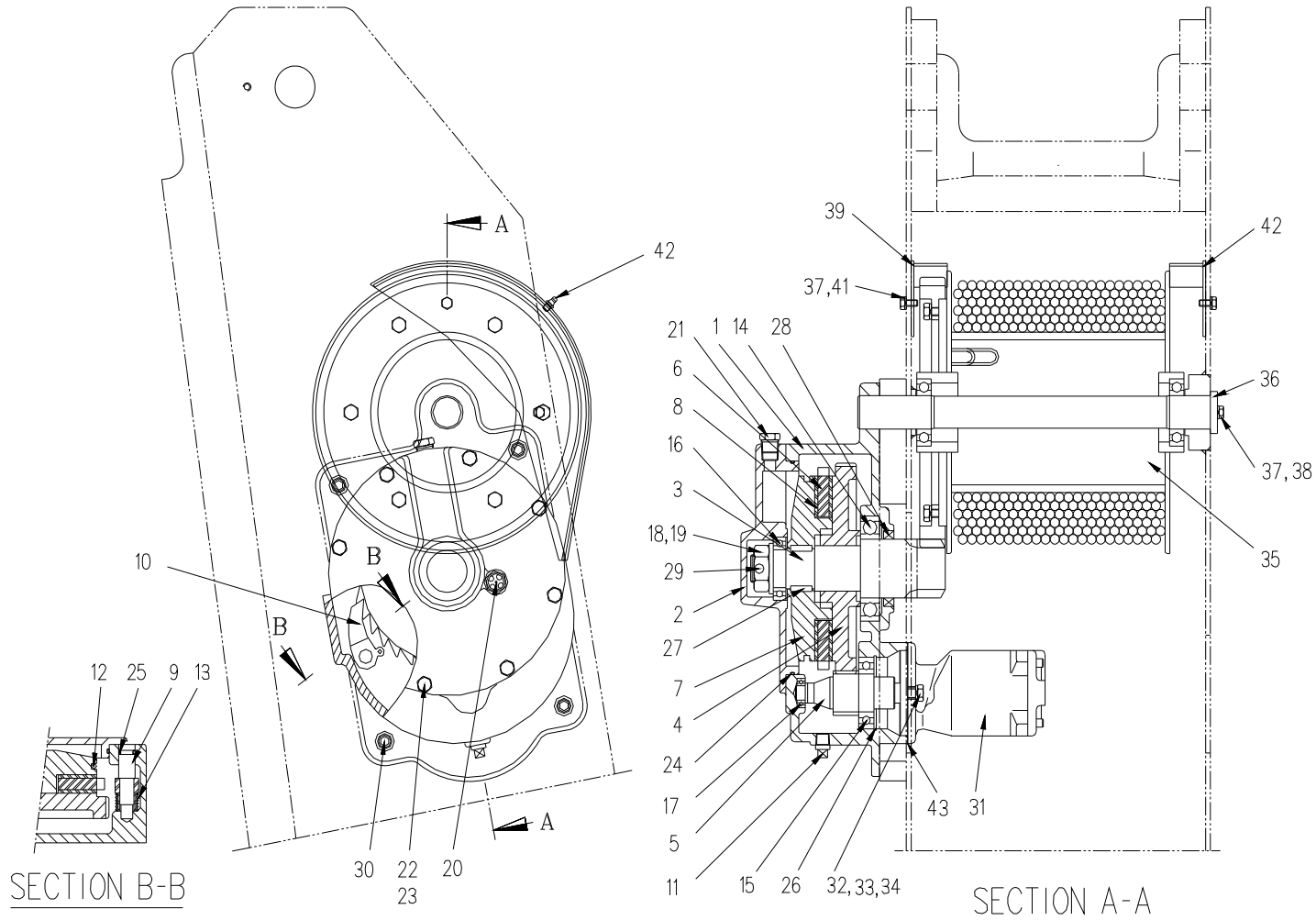

SPARE PARTS LIST



원치 장치
WINCH SYSTEM

HIAB190T-6 13:0
2013. 01.

번호 No.	부품 번호 Part No.	품명 Description	수량 Q'ty	비고 Remarks	번호 No.	부품 번호 Part No.	품명 Description	수량 Q'ty	비고 Remarks
-	WC-4001	원치 장치 WINCH SYSTEM	1		10	DM-06-11-1010	후크 HOOK	1	
1	DM-06-11-1001	케이스 CASE	1		11	DM-06-11-1011	캡 CAP	1	PT3/8
2	DM-06-11-1002	케이스 커버 COVER, CASE	1		12	DM-06-11-1012	스프링 SPRING	1	
3	DM-06-11-1003	출력 기어 GEAR, OUTPUT	1		13	DM-06-11-1013	스프링 SPRING	1	
4	DM-06-11-1004	스퍼 기어 GEAR, SPUR	1		14	4112144	깊은 홈 볼 베어링 BEARING, RADIAL BALL	1	6214ZZ
5	DM-06-11-1005	입력 기어 GEAR, INPUT	1		15	4112094	깊은 홈 볼 베어링 BEARING, RADIAL BALL	1	6209ZZ
6	DM-06-11-1006	라쳇 RATCHET	1		16	4110094	깊은 홈 볼 베어링 BEARING, RADIAL BALL	1	6009ZZ
7	DM-06-11-1007	디스크 플레이트 PLATE, DISK	1		17	4110034	깊은 홈 볼 베어링 BEARING, RADIAL BALL	1	6003ZZ
8	DM-06-11-1008	디스크 DISK	2		18	DM-06-11-1014	홈 볼이 육각 너트 NUT, SLOT HEX.	1	M33
9	DM-06-11-1009	후크 샤프트 SHAFT, HOOK	1		19	DM-06-11-1015	평 와셔 WASHER, PLAIN	1	M33

SPARE PARTS LIST



원치 장치
WINCH SYSTEM

HIAB190T-6 13 : 0
2013. 01.

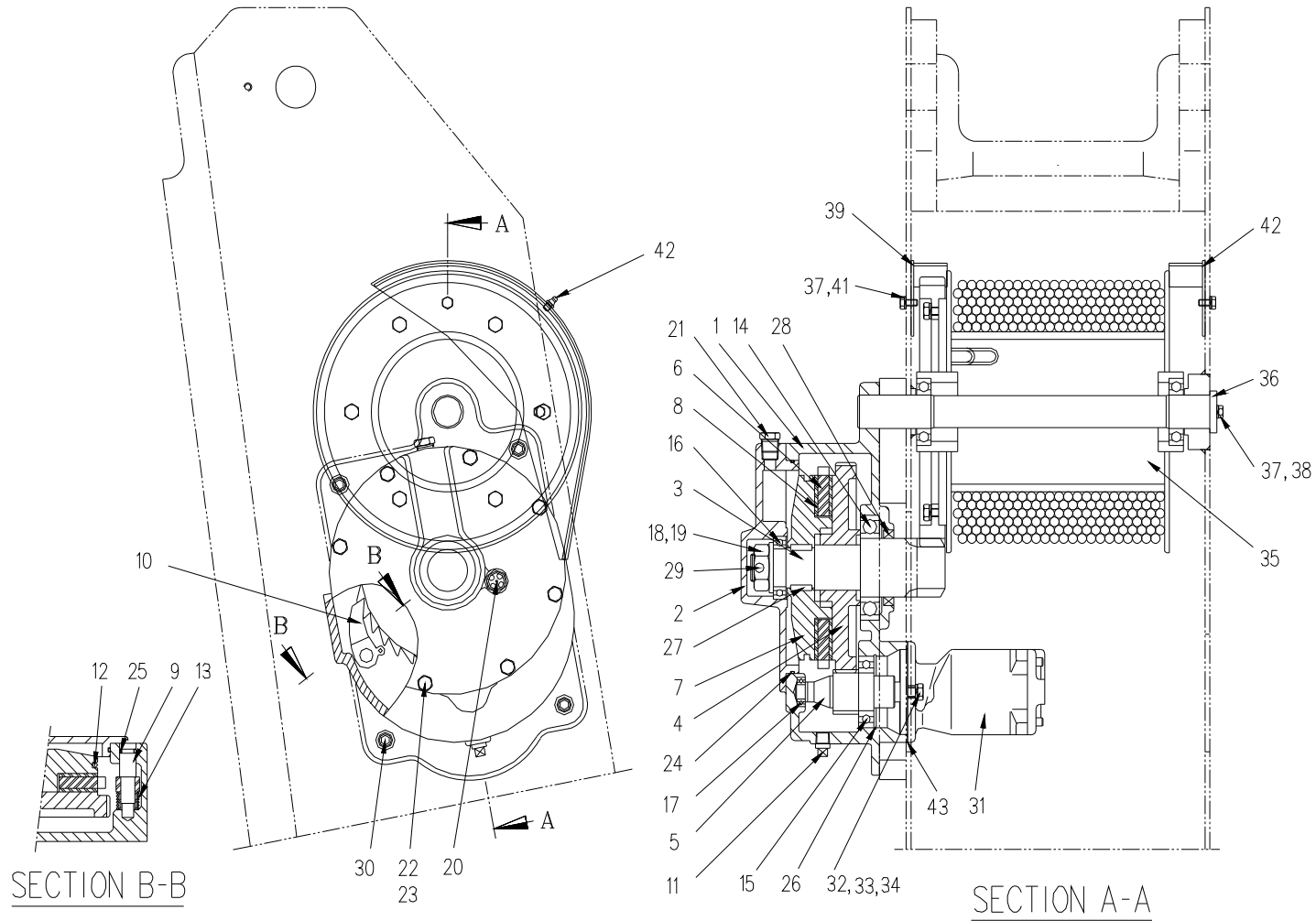

SPARE PARTS LIST



원치 장치
WINCH SYSTEM

HIAB190T-6 13:0
2013. 01.

번호 No.	부품 번호 Part No.	품명 Description	수량 Q'ty	비고 Remarks	번호 No.	부품 번호 Part No.	품명 Description	수량 Q'ty	비고 Remarks
20	DM-06-11-1016	오일 게이지 GAUGE, OIL	1	PF1/2	30	2611547	구멍 볼이 육각 볼트 BOLT, HEX. SOCKET HEAD	4	BB12×40
21	DM-06-11-1017	에어 브리더 BRETHER, AIR	1		31	H02-0104	원치 모터 MOTOR, WINCH	1	JMF-47-01
22	2111206	육각 볼트 BOLT, HEX. HEAD	8	BA10×25	32	2111567	육각 볼트 BOLT, HEX. HEAD	2	BA14×50
23	3612101	스프링 와셔 WASHER, SPRING	8	WS10	33	3511141	평 와셔 WASHER, PLAIN	2	WP14
24	DM-06-11-1018	O-링 O-RING	1	273	34	3612141	스프링 와셔 WASHER, SPRING	2	WS14
25	6010192	O-링 O-RING	1	1B P16	35	WC-4007	드럼 DRUM ASSY	1	
26	4525561	멈춤 링 RING, RETAINING	1	RB85	36	WC-0014	축 SHAFT	1	6208ZZ
27	DM-06-11-1019	평행 키 KEY, PLAIN	2		37	2110926	육각 볼트 BOLT, HEX. HEAD	2	BA8×30
28	DM-06-11-1020	오일 시일 SEAL, OIL	1		38	3612081	스프링 와셔 WASHER, SPRING	6	WS8
29	1311141	분할 핀 PIN, SPLIT	1	PW5×50	39	WC-4013	커버 COVER, LH	1	

SPARE PARTS LIST



원치 장치
WINCH SYSTEM

HIAB190T-6 13 : 0
2013. 01.

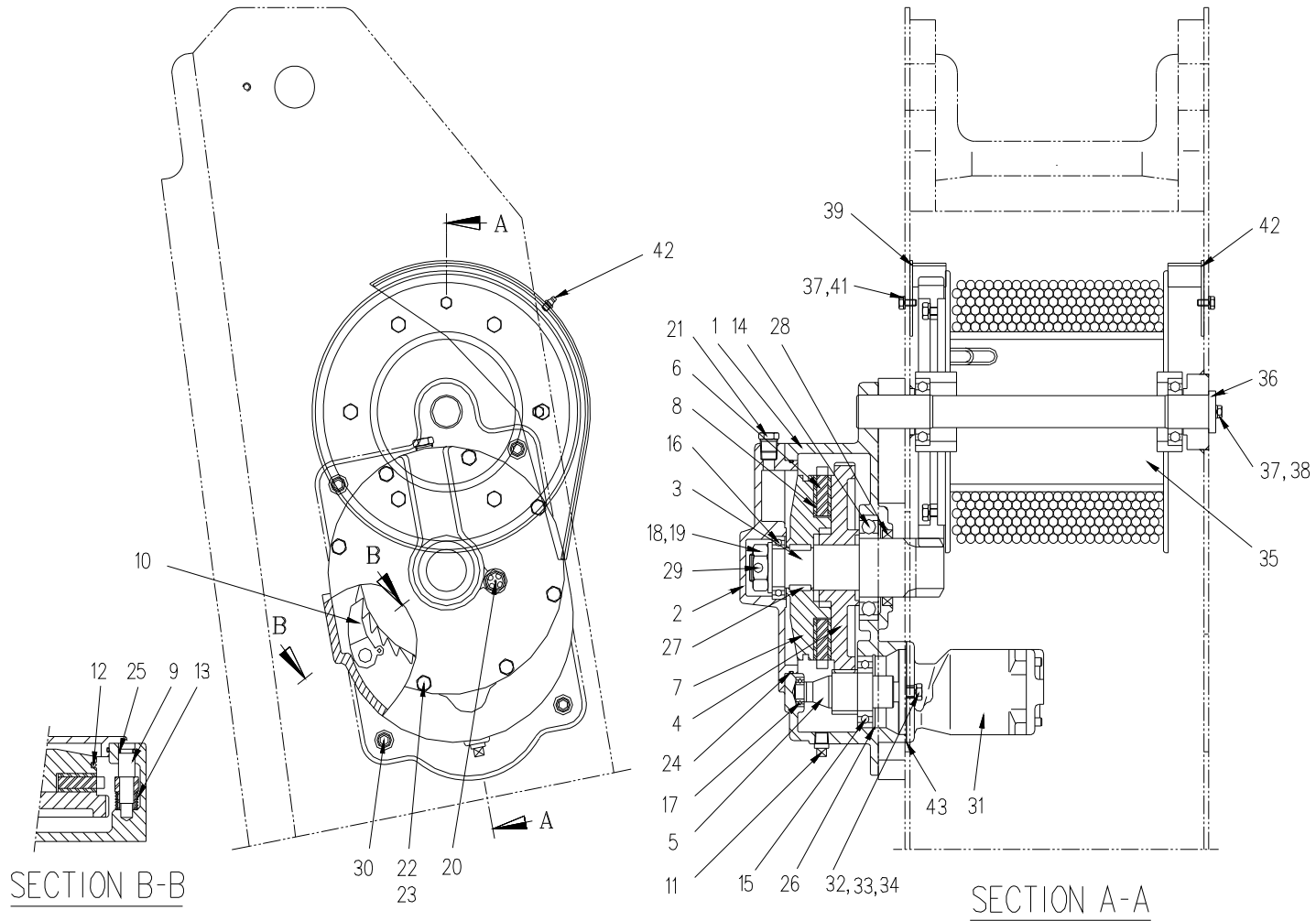

SPARE PARTS LIST



원치 장치
WINCH SYSTEM

HIAB190T-6 13:0
2013. 01.

번호 No.	부품 번호 Part No.	품명 Description	수량 Q'ty	비고 Remarks	번호 No.	부품 번호 Part No.	품명 Description	수량 Q'ty	비고 Remarks
40	WC-4016	커버 COVER, RH	1						
41	2110866	육각 볼트 BOLT, HEX. HEAD	4	BA8×16					
42	4610212	그리스 니플 NIPPLE, GREASE	1	A-M6×1					
43	N01-3202	가스켓 GASKET	1						

SPARE PARTS LIST



선회 감속기
SLEWING REDUCER

HIAB190T-6 14 : 0
2013. 01.

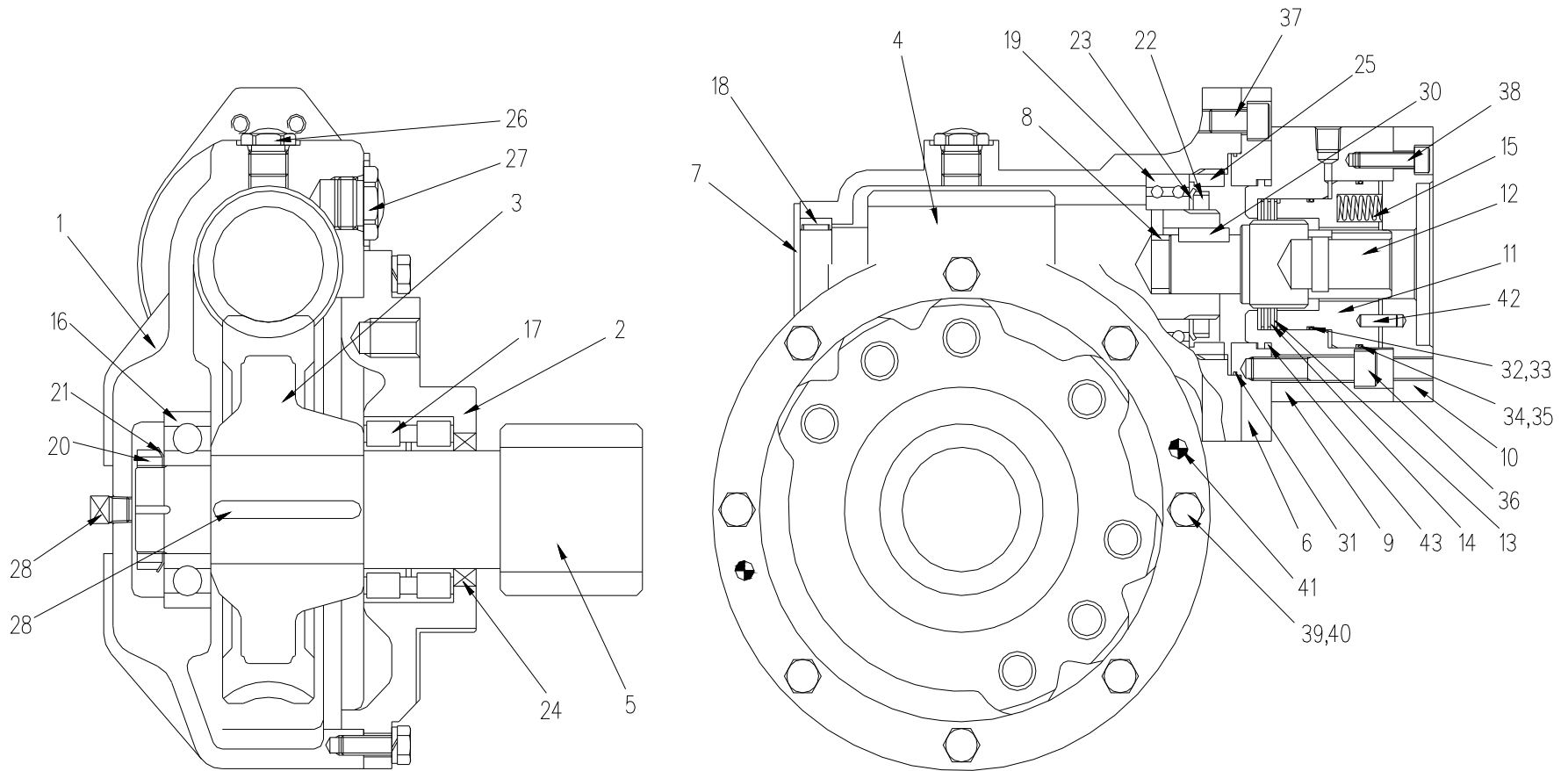

SPARE PARTS LIST



선회 감속기
SLEWING REDUCER

HIAB190T-6 14:0
2013. 01.

번호 No.	부품 번호 Part No.	품명 Description	수량 Q'ty	비고 Remarks	번호 No.	부품 번호 Part No.	품명 Description	수량 Q'ty	비고 Remarks
-	BC1-0003	선회 감속기 SLEWING REDUCER	1		10	07-04-2007	모터 아답터 ADAPTOR, MOTOR	1	
1	07-07-1001	케이스 CASE	1		11	07-04-2037	브레이크 피스톤 PISTON, BRAKE	1	
2	07-07-1002	커버 COVER	1		12	07-04-2909	브레이크 축 SHAFT, BRAKE	1	
3	07-07-1003	웜 기어 GEAR, WORM	1		13	07-04-2033	디스크 DISK	3	
4	07-07-1004	웜 축 SHAFT, WORM	1		14	07-04-2034	플레이트 PLATE	3	
5	07-07-HA05	피니언 축 SHAFT, PINION	1		15	07-04-2018	스프링 SPRING	8	
6	07-07-HA06	아답터 ADAPTOR	1		16	4113092	깊은 홈 볼 베어링 BEARING, RADIAL BALL	1	6309ZZ
7	07-07-1007	플레이트 커버 COVER, PLATE	1		17	BC1-0003-1	롤러 베어링 BEARING, ROLLER	1	SL04-5012
8	07-07-HA08	스페이스 SPACER	1		18	BC1-0003-2	니들 베어링 BEARING, NEEDLE	1	RNA4906
9	07-04-2006	브레이크 하우스 HOUSING, BRAKE	1		19	BC1-0003-3	볼 베어링 BEARING, BALL	1	5210

SPARE PARTS LIST



선회 감속기
SLEWING REDUCER

HIAB190T-6 14 : 0
2013. 01.

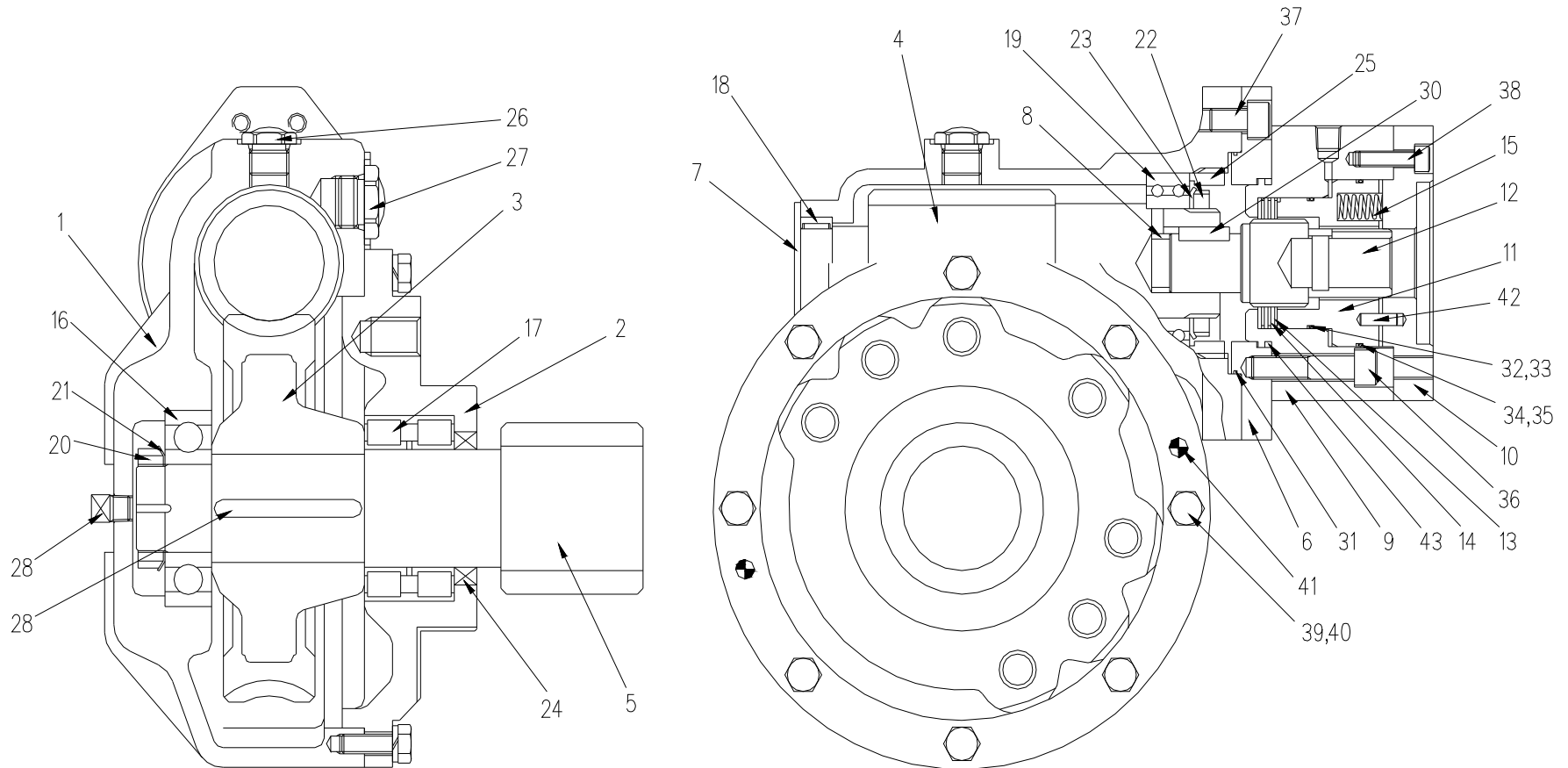

SPARE PARTS LIST



선회 감속기
SLEWING REDUCER

HIAB190T-6 14:0
2013. 01.

번호 No.	부품 번호 Part No.	품명 Description	수량 Q'ty	비고 Remarks	번호 No.	부품 번호 Part No.	품명 Description	수량 Q'ty	비고 Remarks
20	BC1-0003-4	베어링 너트 NUT, BEARING	1	AN09	30	BC1-0003-13	키 KEY	1	
21	BC1-0003-5	베어링 와셔 WASHER, BEARING	1	AW09	31	6012392	O-링 O-RING	1	1B G95
22	BC1-0003-6	베어링 너트 NUT, BEARING	1	AN10	32	6012332	O-링 O-RING	1	1B G65
23	BC1-0003-7	베어링 와셔 WASHER, BEARING	1	AW10	33	6035281	백업 링 RING, BACK-UP	1	T2 G65
24	BC1-0003-8	오일 시일 OIL SEAL	1	607812	34	6012352	O-링 O-RING	1	1B G75
25	07-07-1009	고정 시일 LOCK THREAD	1		35	6035301	백업 링 RING, BACK-UP	1	T2 G75
26	BC1-0003-9	오일 게이지 GAUGE, OIL	1	PF1/2	36	2616576	구멍 볼이 육각 볼트 BOLT, HEX. SOCKET HEAD	6	BB12×55
27	BC1-0003-10	캡 CAP	1	PF3/4	37	2611486	구멍 볼이 육각 볼트 BOLT, HEX. SOCKET HEAD	4	BB12×20
28	BC1-0003-11	플러그 PLUG	1	PT1/2	38	2610926	구멍 볼이 육각 볼트 BOLT, HEX. SOCKET HEAD	6	BB8×30
29	BC1-0003-12	키 KEY	2		39	2111226	육각 볼트 BOLT, HEX. HEAD	8	BA10×30

SPARE PARTS LIST



선회 감속기
SLEWING REDUCER

HIAB190T-6 14 : 0
2013. 01.

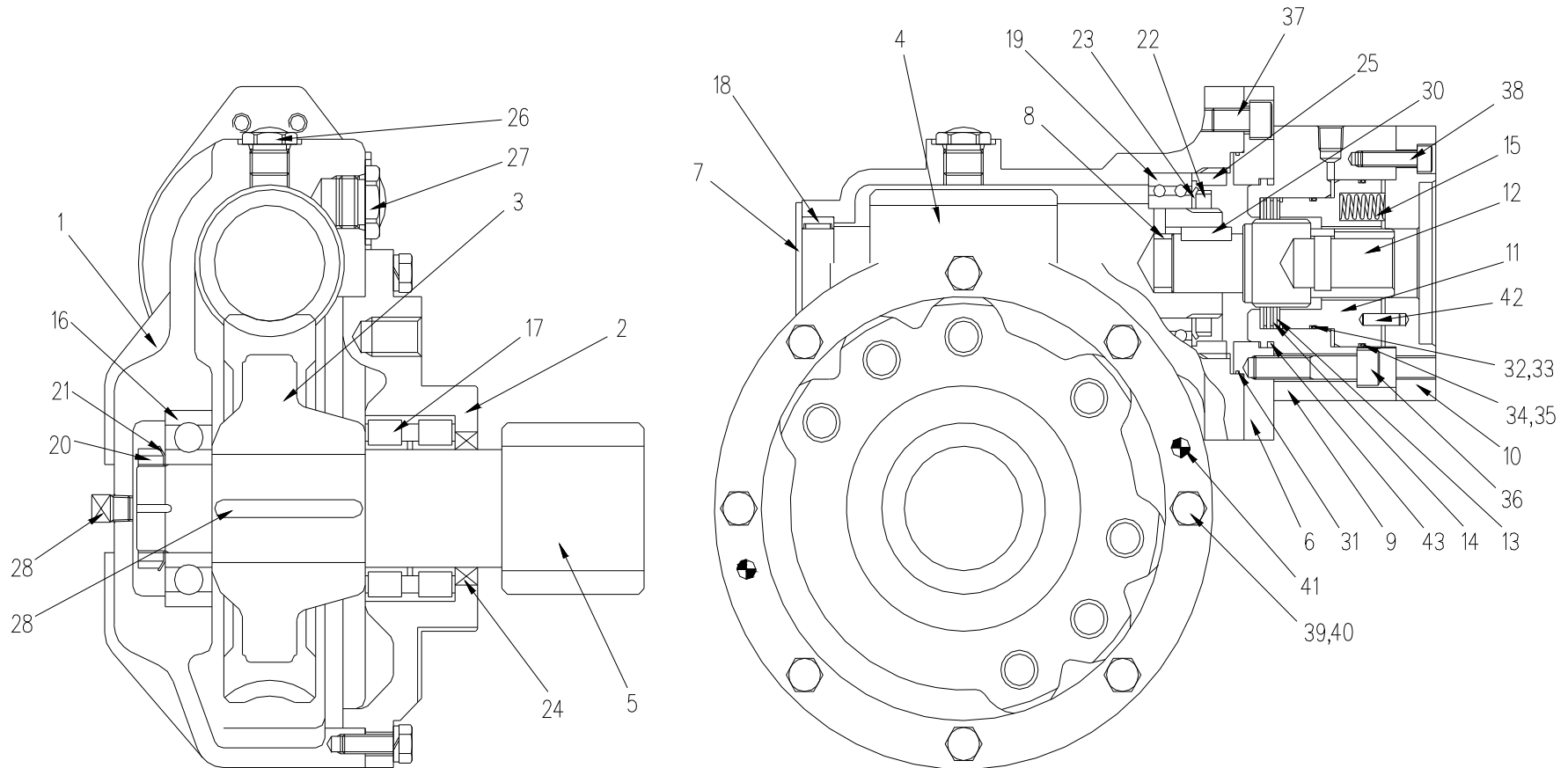

SPARE PARTS LIST



선회 감속기
SLEWING REDUCER

HIAB190T-6 14:0
2013. 01.

번호 No.	부품 번호 Part No.	품 명 Description	수량 Q'ty	비 고 Remarks	번호 No.	부품 번호 Part No.	품 명 Description	수량 Q'ty	비 고 Remarks
40	3612101	스프링 와셔 WASHER, SPRING	1	WS10					
41	BC1-0003-14	핀 PIN	1						
42	BC1-0003-15	핀 PIN	1						
43	6012362	O-링 O-RING	1	1B G80					

SPARE PARTS LIST



선회 모터
SLEWING MOTOR

HIAB190T-6 15:0
2013.01.

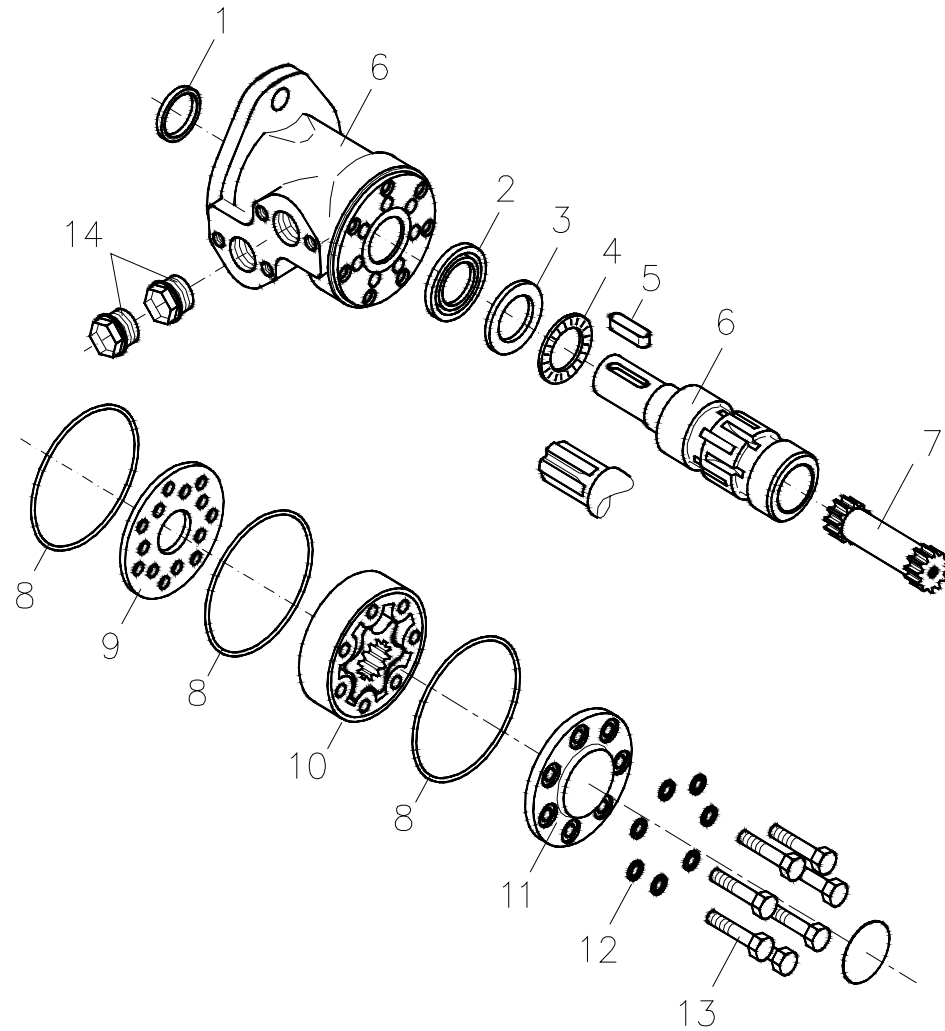

SPARE PARTS LIST



선회 모터
SLEWING MOTOR

HIAB190T-6 15:0
2013. 01.

번호 No.	부품 번호 Part No.	품명 Description	수량 Q'ty	비고 Remarks	번호 No.	부품 번호 Part No.	품명 Description	수량 Q'ty	비고 Remarks
-	H02-0200	선회 모터 SLEWING MOTOR	1	OMP100C	10	151-1128	기어 휠일 세트 GEAR WHEEL SET	1	W=13.0mm
1	633B0010	더스트 시일 링 DUST SEAL RING	1	35.0×28.5×4.0mm	11	151-1459	커버 END COVER	1	
2	633B0361	축 시일 SHAFT SEAL	1	39.0×28.6×4.9mm, HSN	12	684X0115	와셔 WASHER	7	15.2×8.2×1.0mm
3	151-1608	베어링 레이스 BEARING RACE	1	47.5×29.5×3.0mm	13	681X0180	스크루 SCREW	7	l=40mm
4	151-1458	축 니들 베어링 AXIAL NEEDLE BEARING	1	42.0×28.7×4.5mm	14	633X0074	플러그 PLUG	2	
5	682L9007	평행 키 PARALLEL KEY	1	A8×7×31mm					
6	-	하우징 + 아웃풋 축 HOUSING + OUTPUT SHAFT	1						
7	151-2645	카아단 축 CARDAN SHAFT	1	L=83.3mm					
8	633B1173	오링 O-RING	3	75.9×1.8mm, NBR	-	151-1286	시일 키트 KIT, SEAL	1	
9	151-1713	분배 플레이트 DISTRIBUTOR PLATE	1						

SPARE PARTS LIST



카운터 발란스 밸브
COUNTER BALANCE VALVE (D)

HIAB190T-6 16 : 0
2013. 01.

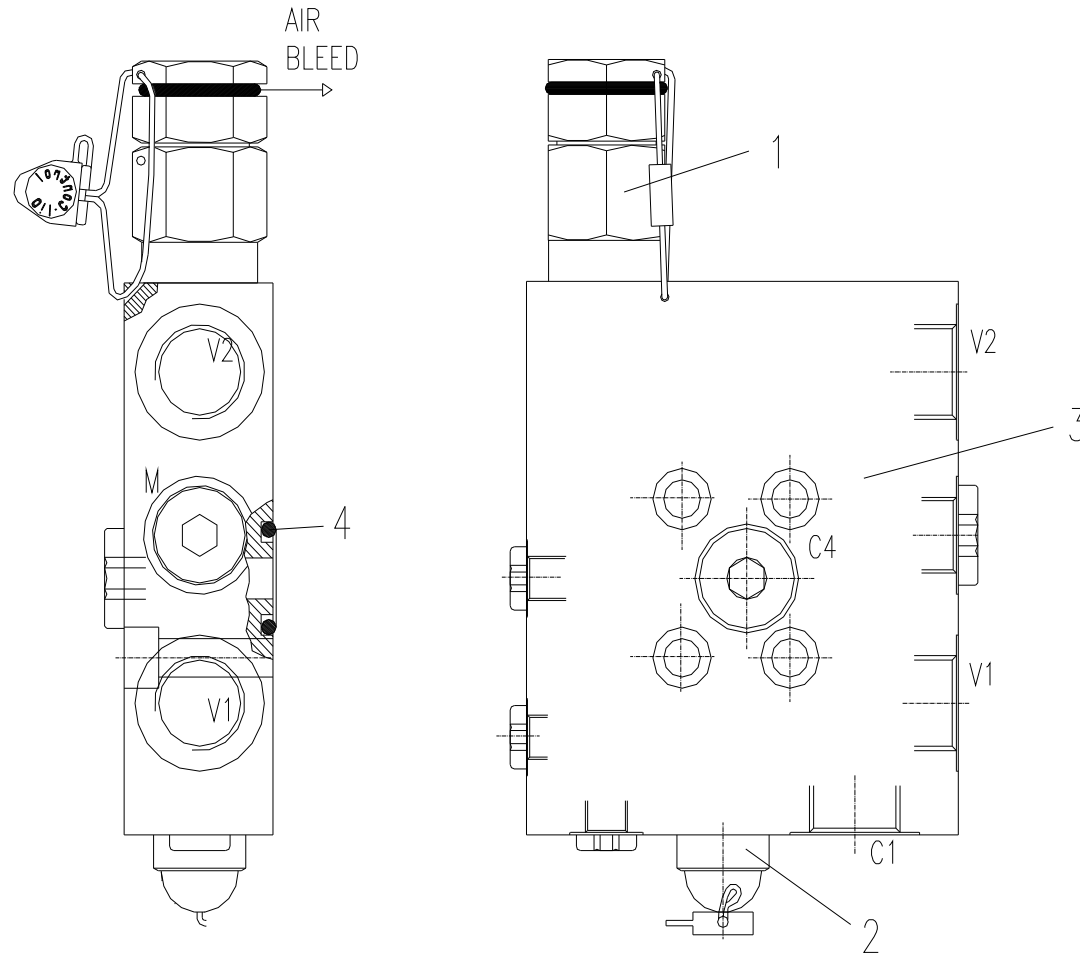

SPARE PARTS LIST



카운터 밸런스 밸브
COUNTER BALANCE VALVE (D)

HIAB190T-6 16:0
2013. 01.

번호 No.	부품 번호 Part No.	품명 Description	수량 Q'ty	비고 Remarks	번호 No.	부품 번호 Part No.	품명 Description	수량 Q'ty	비고 Remarks
-	986 8381	카운터 밸런스 밸브 COUNTER BALANCE VALVE (E)	1						
1	()	밸브 VALVE	1	VBSO-SE90 390BAR					
2	()	밸브 VALVE	1	VS5 270 BAR					
3	()	바디 BODY	1						
4	984 4899	오링 O-RING	1						

SPARE PARTS LIST



데릭 실린더
DERRICK CYLINDER

HIAB190T-6 17:0
2013. 01.

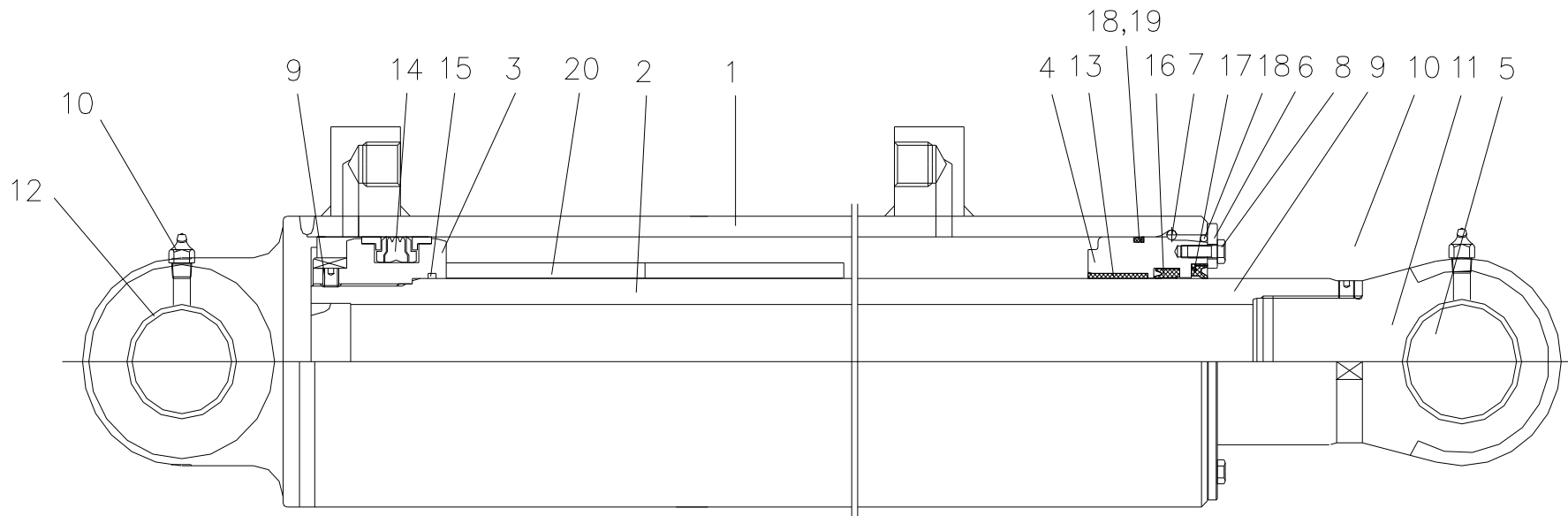

SPARE PARTS LIST



데릭 실린더
DERRICK CYLINDER

HIAB190T-6 17:0
2013. 01.

번호 No.	부품 번호 Part No.	품명 Description	수량 Q'ty	비고 Remarks	번호 No.	부품 번호 Part No.	품명 Description	수량 Q'ty	비고 Remarks
-	H01-5001	데릭 실린더 DERRICK CYLINDER	1	HN88D0000	11	S01-1889	DX 부싱 BUSHING, DX	2	PM 5530 DX
1	HN88D0010	튜브 결합체 TUBE ASS'Y	1		12	4325441	DX 부싱 BUSHING, DX	2	PM 5540 DX
2	HN88D0020	로드 결합체 ROD ASS'Y	1		13	S01-4642	DU 부싱 BUSHING, DU	1	MB 8030 DU
3	HN20IB040	피스톤 PISTON	1		14	S01-1890	피스톤 패킹 PISTON PACKING	1	PCB 0A1200-NCRO *
4	HN51D0040	로드 커버 ROD COVER	1		15	6012362	오링 O - RING	1	1B G80 *
5	HN43D0030	로드 헤드 ROD HEAD	1		16	S01-2735	로드 패킹 ROD PACKING	1	NI-300 *
6	HN51D0050	커버 COVER	1	Φ128×Φ90×5T	17	6112091	더스트 와이퍼 DUST WIPER	1	KWU 80 *
7	HN51D0060	멈춤 링 RETAINING RING	1	Φ110×5T	18	6012432	오링 O - RING	2	1B G115 *
8	H01-2674	육각 볼트 HEX. BOLT	4	M6×P1.0×15L	19	6035841	백업 링 RING, BACK-UP	1	T3 G115 *
9	2350556	멈춤 나사 SCREW, SET	1	M8×P1.25×8L	20	SSA8E0050	스페이서 SPACER	2	Φ80.5×Φ95×100L
10	4610702	그리스 니플 NIPPLE, GREASE	2	PT 1/8-A	-	S01-1892	시일 키트 KIT, SEAL	1	PARTS MARKED *

SPARE PARTS LIST



로타리 조인트 결합체
ROTARY JOINT ASS'Y

HIAB190T-6 18:0
2013. 01.

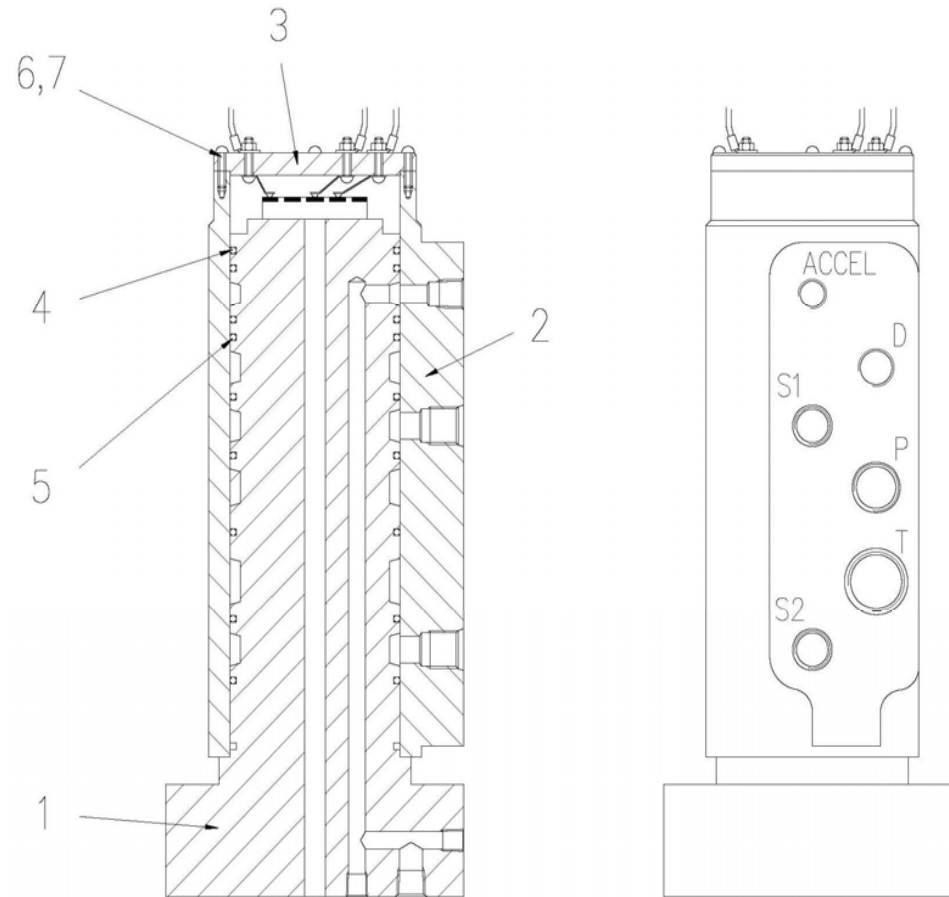

SPARE PARTS LIST



로타리 조인트 결합체
ROTARY JOINT ASS'Y

HIAB190T-6 18:0
2013. 01.

번호 No.	부품 번호 Part No.	품명 Description	수량 Q'ty	비고 Remarks	번호 No.	부품 번호 Part No.	품명 Description	수량 Q'ty	비고 Remarks
-	A02-1740	로타리 조인트 결합체 ROTART JOINT ASS'Y	1						
1	M01-1242	축 바디 링 SHAFT BODY RING	1						
2	N01-3297	실린더 CYLINDER	1						
3	N01-3224	슬립 링 결합체 SLIP RING ASSY	1						
4	N01-3225	로토그리드 링 ROTOGLYD RING	8	STR80					
5	N01-3226	쿼드 링 QUAD RING	2	Φ70					
6	N01-3227	작은 나사 SCREW, MACHINE	4	M4×20					
7	3612041	스프링 와셔 WASHER, SPRING	4	WS4					

SPARE PARTS LIST



운전석 결합체
TOP SEAT ASS'Y

HIAB190T-6 19:0
2013. 01.

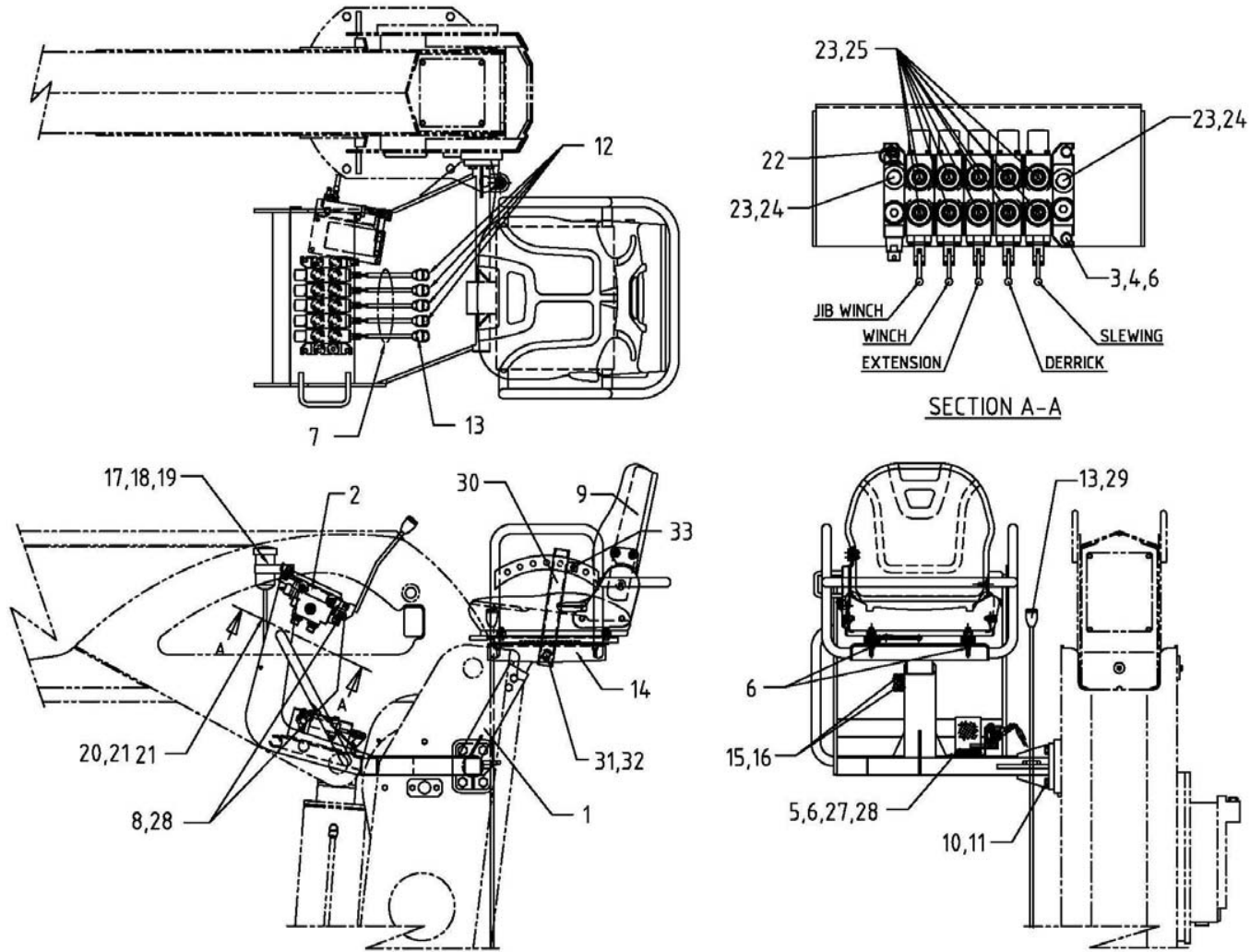

SPARE PARTS LIST



운전석 결합체
TOP SEAT ASS'Y

HIAB190T-6 19:0
2013. 01.

번호 No.	부품 번호 Part No.	품명 Description	수량 Q'ty	비고 Remarks	번호 No.	부품 번호 Part No.	품명 Description	수량 Q'ty	비고 Remarks
-	A01-0538	운전석 결합체 TOP SEAT ASSY	1		10	2112137	육각 볼트 BOLT, HEX. HEAD	4	BA16×35
1	A02-2523	운전석 구조물 STRU., TOP SEAT	1		11	3612161	스프링 와셔 WASHER, SPRING	4	WS16
2	H02-0290	주 제어 밸브 VALVE, MAIN CONTROL	1	RS215	12	S01-0047	손잡이 KNOB	3	BLACK
3	2115997	육각 볼트 BOLT, HEX. HEAD	4	BA8×65	13	S01-0048	손잡이 KNOB	2	RED
4	3511081	평 와셔 WASHER, PLAIN	4	WP8	14	A02-2398	의자 브라켓 BRACKET, SEAT	1	
5	A02-1778	악셀 페달 마운팅 ACCEL PEDAL MTG.	1		15	2111546	육각 볼트 BOLT, HEX. HEAD	2	BA12×40
6	S01-0005	셀프 로킹 너트 NUT, SELF LOCKING	7	M8	16	3111126	육각 너트 NUT, HEX.	2	NA12
7	TS-0043	레버 LEVER	4		17	TS-0029	오일 탱크 TANK, OIL	1	
8	S01-0049	핀 PIN	8		18	TS-0030	오일 탱크 밴드 BAND, OIL TANK	1	
9	S01-2216	의자 SEAT	1		19	2110926	육각 볼트 BOLT, HEX. HEAD	1	BA8×30

SPARE PARTS LIST



운전석 결합체
TOP SEAT ASS'Y

HIAB190T-6 19:0
2013. 01.

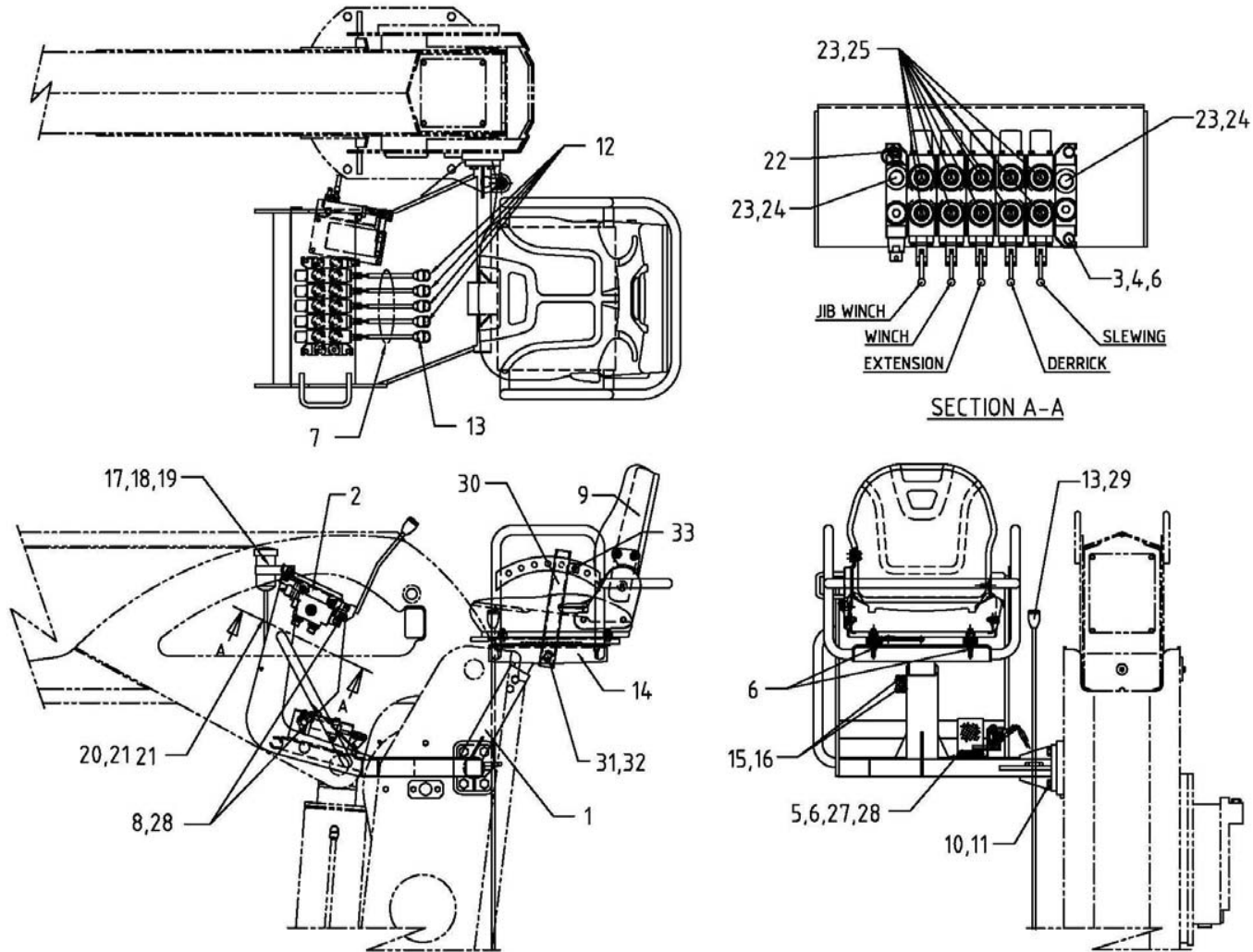

SPARE PARTS LIST



운전석 결합체
TOP SEAT ASS'Y

HIAB190T-6 19:0
2013. 01.

번호 No.	부품 번호 Part No.	품명 Description	수량 Q'ty	비고 Remarks	번호 No.	부품 번호 Part No.	품명 Description	수량 Q'ty	비고 Remarks
20	TS-0031	비닐 튜브 TUBE, VINYL	1		30	A05-2500	파이프 PIPE, UMBRELLA	1	
21	7811011	호스 클램프 CLAMP, HOSE	2	CH6	31	3511201	평 와셔 WASHER, PLAIN	1	WP20
22	998 9676	게이지 니플 NIPPLE, GAUGE	1		32	4510211	멈춤 링 RING, RETAINING	1	RS20
23	6800081	실링 와셔 WASHER, SEALING	12	NF216-8	33	S01-2891	손잡이 KNOB	1	M12×50
24	9270432	호스 유니언 UNION, CONICAL	2	UC3/4×1/2					
25	9270072	호스 유니언 UNION, CONICAL	8	UC1/2×1/2					
26	2110886	육각 볼트 BOLT, HEX. HEAD	3	BA8×20					
27	3612081	스프링 와셔 WASHER, SPRING	3	WS8					
28	4551091	멈춤 링 RING, RETAINING	8	RE6					
29	M01-1060	레버 LEVER	1	Φ10×1430L					

SPARE PARTS LIST



운전석 배관도
TOP SEAT HOSES

HIAB190T-6 20:0
2013. 01.

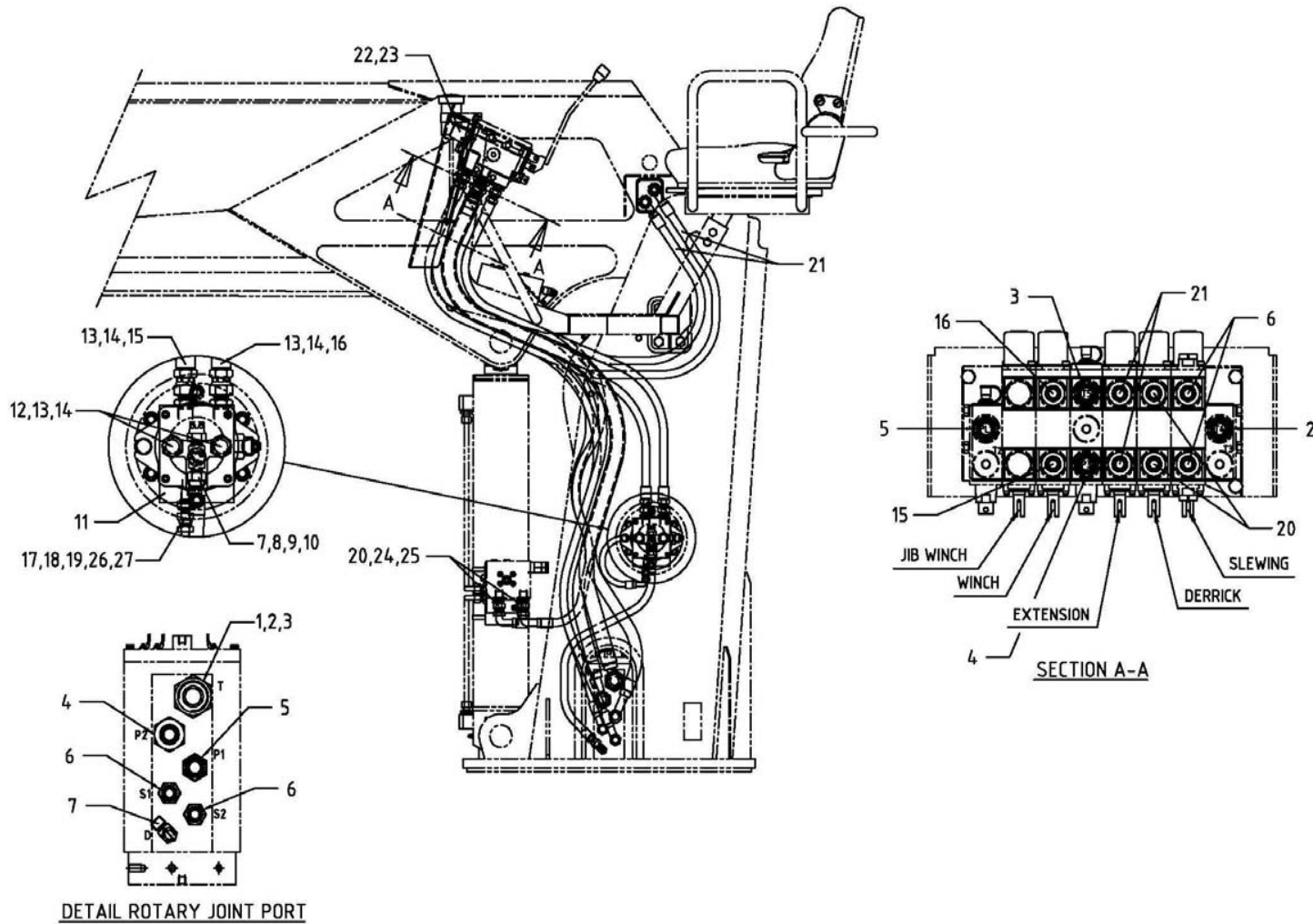

SPARE PARTS LIST



운전석 배관도
TOP SEAT HOSES

HIAB190T-6 20:0
2013. 01.

번호 No.	부품 번호 Part No.	품명 Description	수량 Q'ty	비고 Remarks	번호 No.	부품 번호 Part No.	품명 Description	수량 Q'ty	비고 Remarks
-	A01-0795	운전석 배관도 TOP SEAT HOSES	1		10	7173903	고압 호스 HOSE, H.P (HECF)	2	1/2×1250-PF1/2
1	7170592	고압 호스 HOSE, H.P (HECF)	1	3/8×480-PF3/8	11	9270072	코니칼 유니온 UNION, CONICAL	2	PF1/2×PF1/2
2	N01-3217	롱 니플 NIPPLE, LONG	1	PF3/8×PF3/8	12	7172623	고압 호스 HOSE, H.P (HECF)	2	3/8×1800-PF1/2
3	6010172	O-RING O-RING	1	1B P14	13	7118723	고압 호스 HOSE, H.P (HUCF)	2	3/8×2100-PF1/2
4	7172633	고압 호스 HOSE, H.P (HECF)	1	3/8×1820-PF1/2	14	W01-4128	커버 COVER	1	t=1.6
5	7172663	고압 호스 HOSE, H.P (HECF)	1	3/8×1900-PF1/2	15	S01-2575	윙 볼트 BOLT, WING	4	M8×P1.25
6	7178563	고압 호스 HOSE, H.P (HECF)	1	3/4×1650-PF3/4	16	TS 0038	호스 클램프 CLAMP, HOSE	1	
7	7178673	고압 호스 HOSE, H.P (HECF)	1	3/4×1920-PF3/4	17	2180936	플렌지 붙이 육각 볼트 BOLT, HEX. HEAD W/F	1	BWF8×35
8	N01-3218	롱 니플 NIPPLE, LONG	2	PF1/2×PF1/2	18	H01-0901	호스 스위블 티 TEE, HOSE SWIVEL	1	3-PF3/8
9	6010212	O-링 O-RING	2	1B P18	19	6800081	실링 와셔 WASHER, SEALING	1	NF1/2

SPARE PARTS LIST



주 제어 밸브
MAIN CONTROL VALVE

HIAB190T-6 21:0
2013. 01.

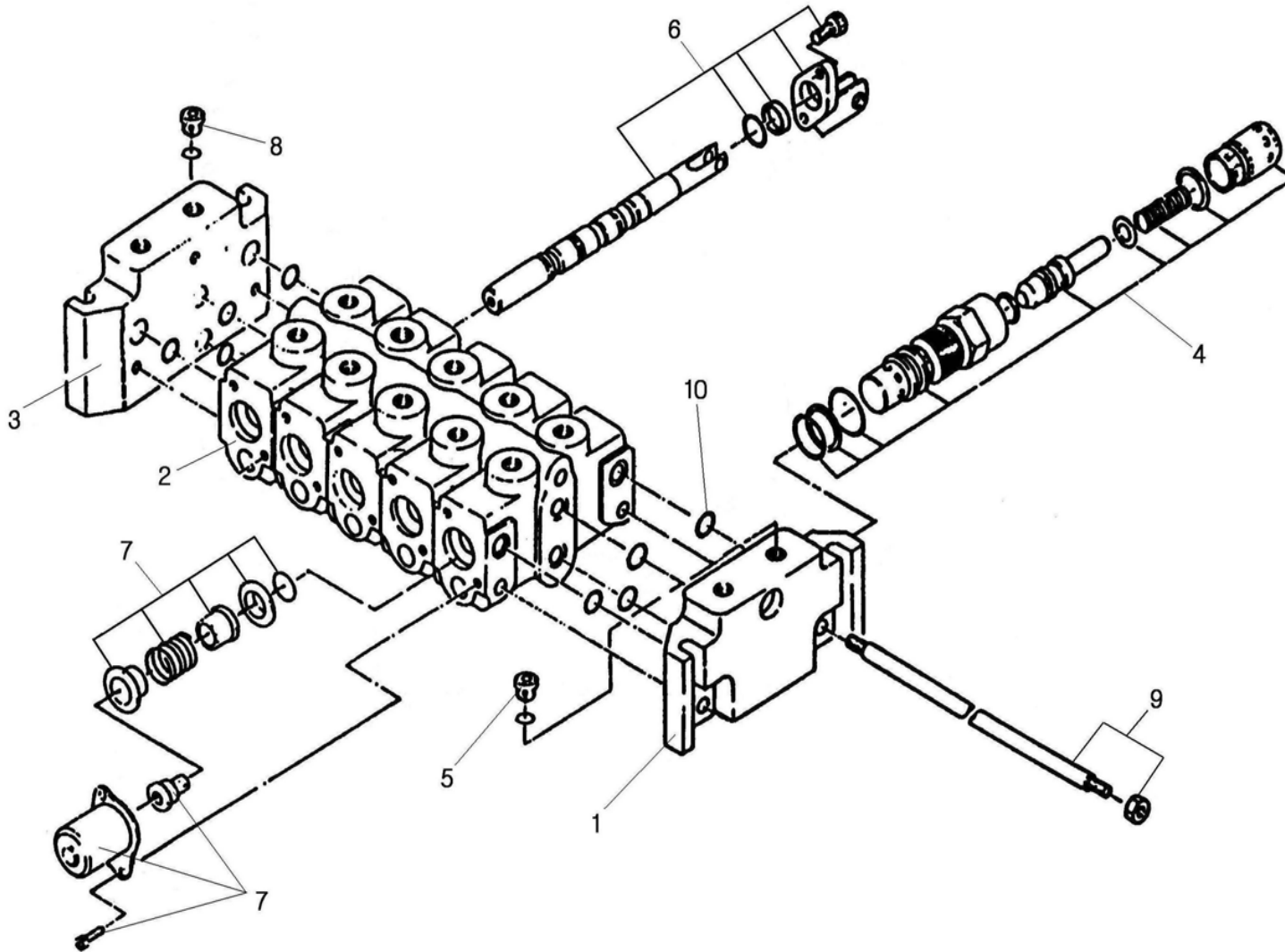

SPARE PARTS LIST



주 제어 밸브
MAIN CONTROL VALVE

HIAB190T-6 21:0
2013. 01.

번호 No.	부품 번호 Part No.	품 명 Description	수량 Q'ty	비 고 Remarks	번호 No.	부품 번호 Part No.	품 명 Description	수량 Q'ty	비 고 Remarks
-	H02-0290	주 제어 밸브 MAIN CONTROL VAVLE			-		스페이서 SPACER	1	
1	2330-26982	PT 블록 PT BLOCK	1		-		포핏 POPPET	1	
2	2330-263162	워크 블록 WORK BLOCK	5	RS210	-	※	백업 링 RING, BACK-UP	1	
3	2330-260984	엔드 블록 END BLOCK	1		-	※	O-링 O-RING	1	12.3×2.4
4	2330-210203	메인 릴리프 밸브 VALVE, MAIN RELIEF	1		5	2330-450059	포트 플러그 결합체 PORT PLUG ASS'Y	1	1/2" BSP
-		조절 스크류 SCREW, ADJUSTING	1		-		포트 플러그 PORT PLUG	1	
-		O-링 O-RING	1	13.3×2.4	-		O-링 O-RING	1	17.3×2.4
-		부싱 BUSHING	1		6	2330-266992	브라켓 BRACKET 3-POSITIONS ASSY	5	9 : 1
-	※	O-링 O-RING	1	17.3×2.4	-		브라켓 BRACKET	1	
-		스프링 SPRING	1		-	★	스크레이퍼 링 SCRAPER RING	1	

SPARE PARTS LIST



주 제어 밸브
MAIN CONTROL VALVE

HIAB190T-6 21:0
2013. 01.

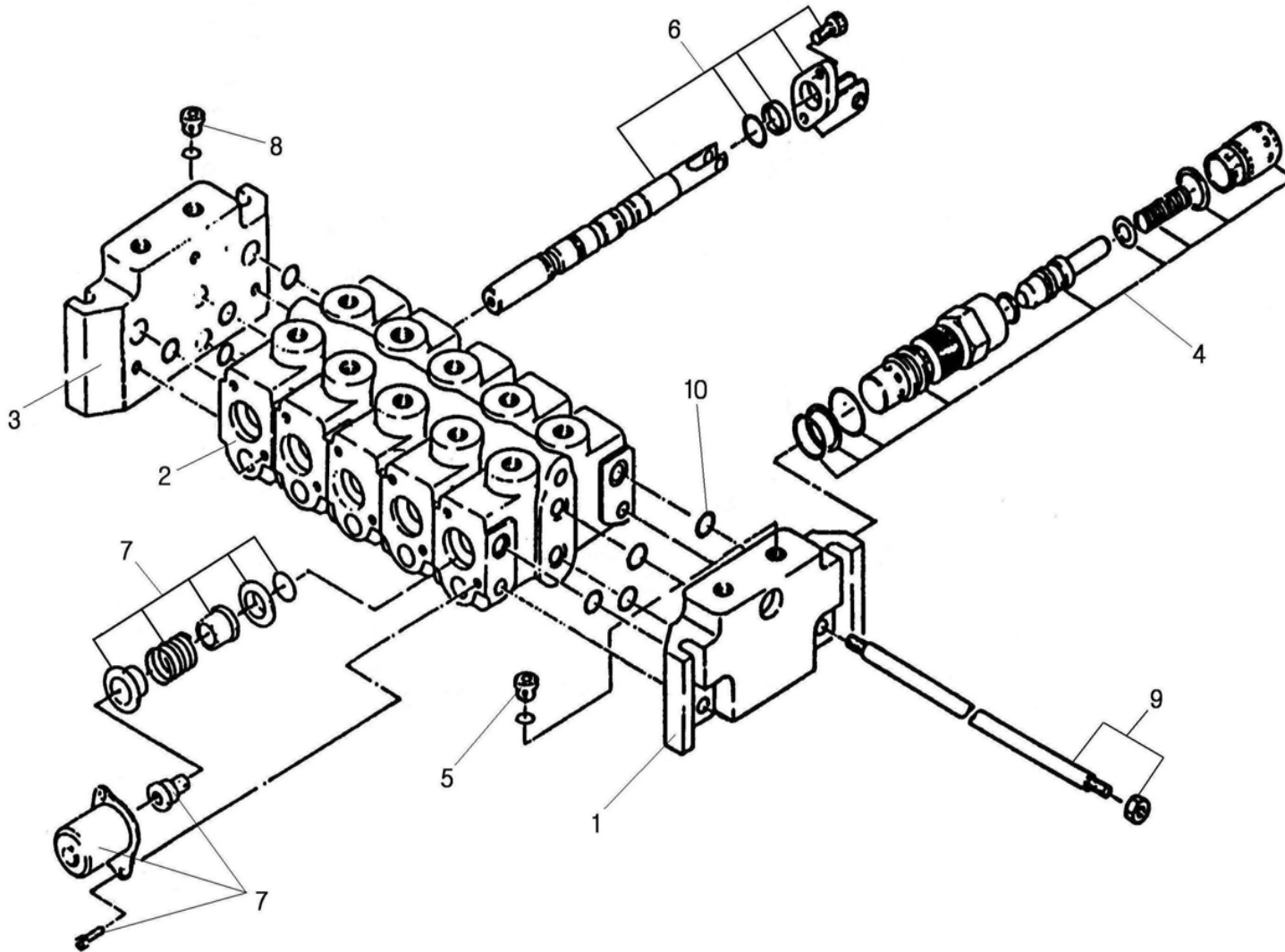

SPARE PARTS LIST



주 제어 밸브
MAIN CONTROL VALVE

HIAB190T-6 21:0
2013. 01.

번호 No.	부품 번호 Part No.	품명 Description	수량 Q'ty	비고 Remarks	번호 No.	부품 번호 Part No.	품명 Description	수량 Q'ty	비고 Remarks
-	★	스풀 시일 결합체 SPOOL SEAL ASS'Y	1		-		스프링 SPRING	1	
-		스크류 SCREW	2		8	2330-450073	캐리 오버 플러그 결합체 CARRY OVER PLUG ASS'Y	1	
7	2330-260944	스풀 컨트롤 결합체 SPOOL CONTROL ASS'Y	5		-		플러그 PLUG	1	
-	★	스풀 시일 SEAL, SPOOL	1		-		O-링 O-RING	1	13.1×2.62
-		와셔 WASHER	1		9	2330-263395	타이 로드 키트 TIE ROD KIT	1	5 SECTION
-		스크류 SCREW	2		-		타이 로드 TIE ROD	3	
-		캡 CAP	1		-		너트 NUT	3	
-		스프링 가이드 GUIDE, SPRING	1		10	2330-260584	내부 섹션 시일 키트 INTER SECTION SEAL KIT	6	
-		스펙싱 스크류 SCREW, SPACING	1		-		O-링 O-RING	3	15.3×2.4
-		스프링 가이드 GUIDE, SPRING	1		-		O-링 O-RING	1	12.3×2.4

SPARE PARTS LIST



주 제어 밸브
MAIN CONTROL VALVE

HIAB190T-6 21:0
2013. 01.

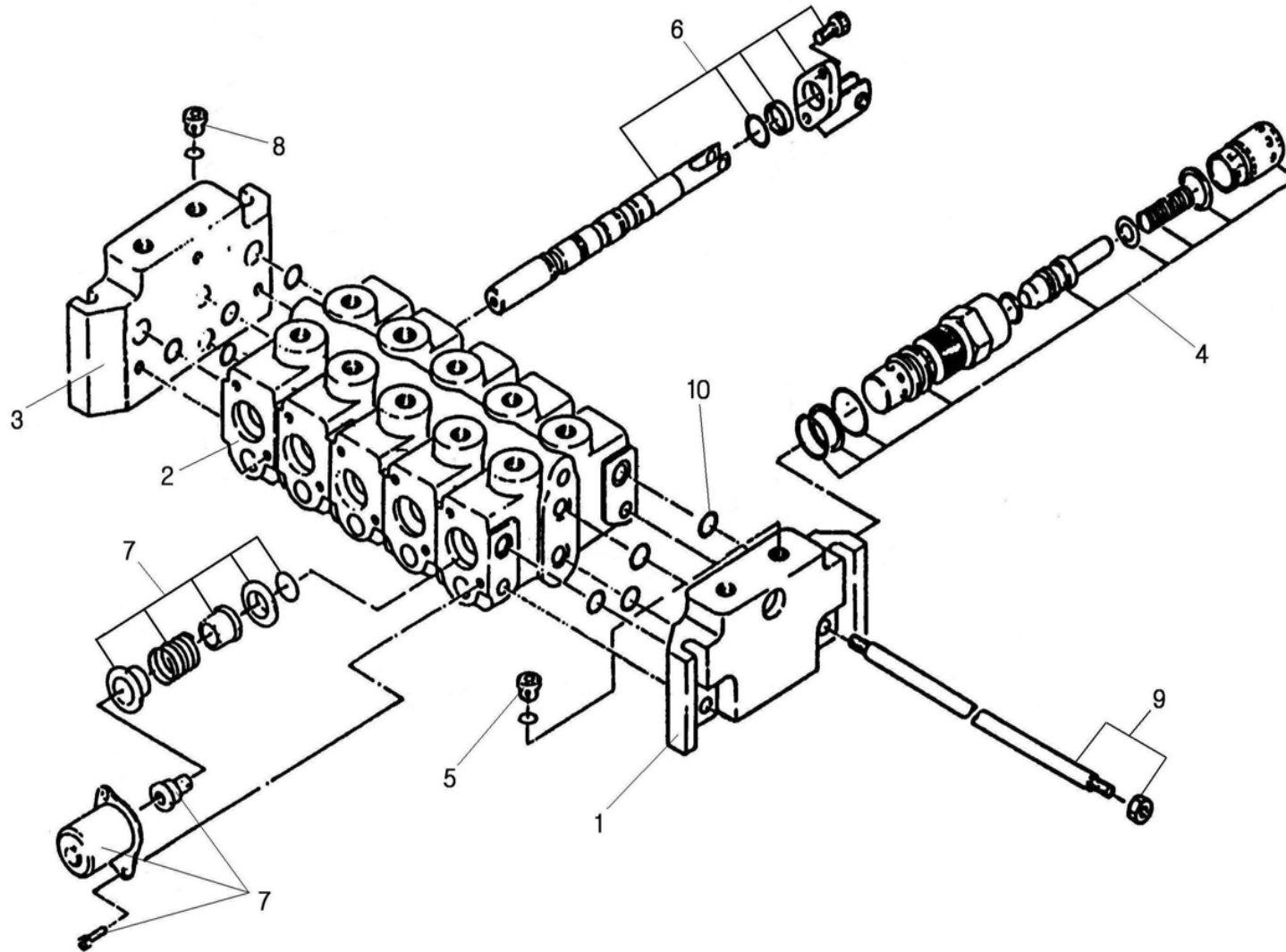

SPARE PARTS LIST



주 제어 밸브
MAIN CONTROL VALVE

HIAB190T-6 21:0
2013.01.

번호 No.	부품 번호 Part No.	품 명 Description	수량 Q'ty	비 고 Remarks	번호 No.	부품 번호 Part No.	품 명 Description	수량 Q'ty	비 고 Remarks
-	2330-260588	메인 시일 키트 MAIN SEAL KIT		PART MARKED ※					
-	2330-260552	스풀 시일 키트 SPOOL SEAL KIT		PART MARKED ★					

SPARE PARTS LIST



아우트리거 결합체
OUTRIGGER ASS'Y

HIAB190T-6 22 : 0
2013. 01.

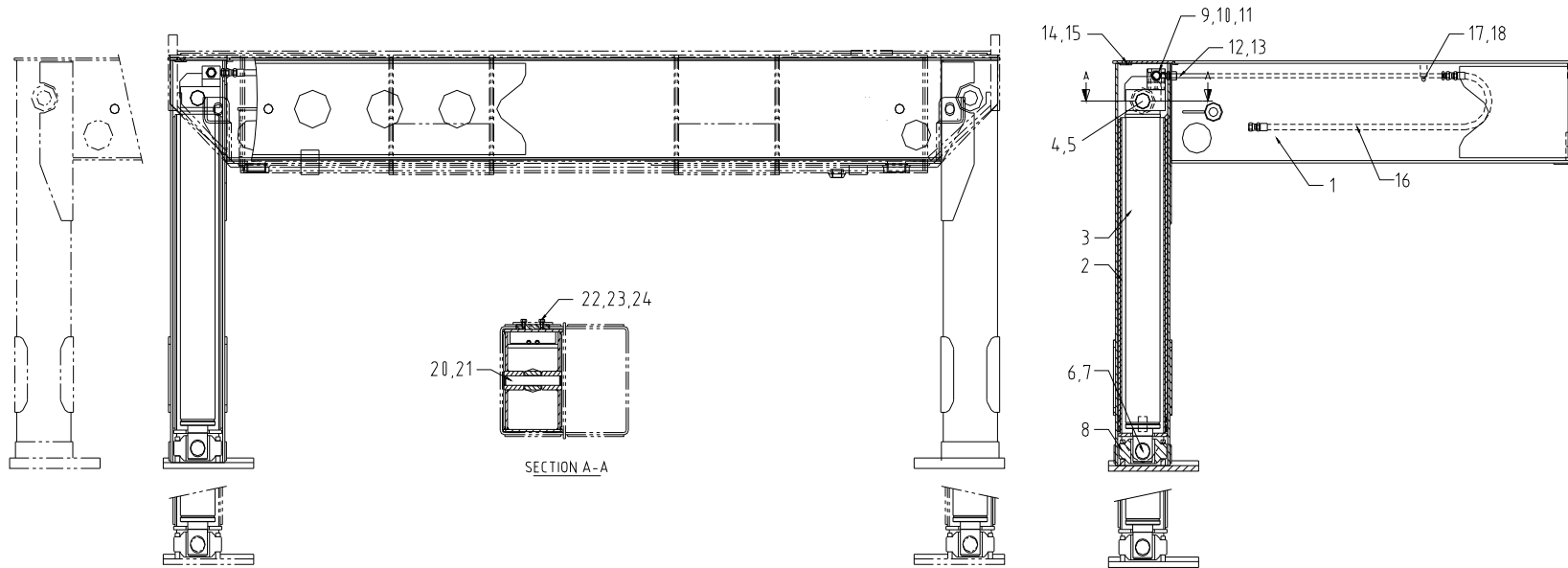
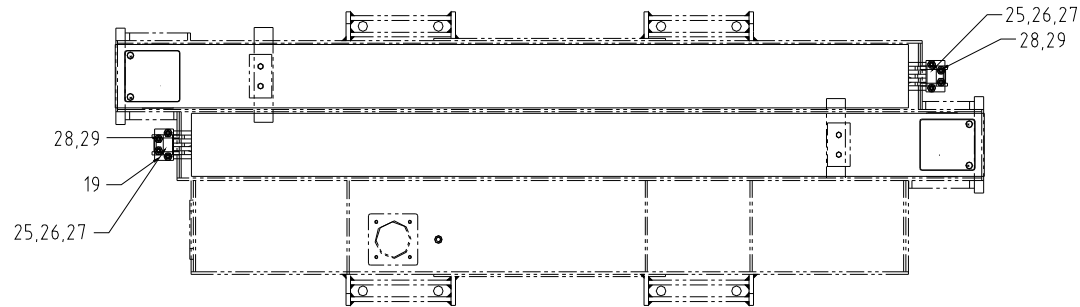

SPARE PARTS LIST



아우트리거 결합체
OUTRIGGER ASS'Y

HIAB190T-6 22 : 0
2013. 01.

번호 No.	부품 번호 Part No.	품명 Description	수량 Q'ty	비고 Remarks	번호 No.	부품 번호 Part No.	품명 Description	수량 Q'ty	비고 Remarks
-	OR1-4001	아우트리거 장치 OUTRIGGER SYSTEM	1		10	6010142	O-링 O-RING	4	1B P12
1	OR1-4003	아우트리거 빔 BEAM, OUTRIGGER	2		11	2615586	구멍 붙이 육각 볼트 BOLT, HEX. SOCKET HEAD	8	BB6×60
2	A05-0970	내부 튜브 TUBE, INNER	2		12	9002512	파이프 니플 NIPPLE, PF PIPE	4	NTP10-PT1/4
3	H01-2066	아우트리거 실린더 OUTRIGGER CYLINDER	2		13	H01-1355	유압 파이프 PIPE, HYDRAULIC	4	Φ10×t1.5
4	OR1-4010	핀 PIN	2		14	A05-0755	커버 COVER	2	
5	4525351	멈춤 링 RING, RETAINING	4	RB40	15	2241606	작은 나사 SCREW, MACHINE	4	BC6×8
6	S01-0754	축 SHAFT	2		16	7113892	고압 호스 HOSE, H.P (HUCF)	4	1/4×1220-PF1/4
7	4510351	멈춤 링 RING, RETAINING	2	RS40	17	M01-0745	핀 PIN	2	
8	OR1-4011	슈 SHOE ASSY	2		18	4551121	멈춤 링 RING, RETAINING	4	RE9
9	H02-1058	파일럿 체크 밸브 VALVE, PILOT CHECK	2		19	H01-1431	사이드 쉬프트 실린더 SIDE SHIFT CYLINDER	2	

SPARE PARTS LIST



아우트리거 결합체
OUTRIGGER ASS'Y

HIAB190T-6 22 : 0
2013. 01.

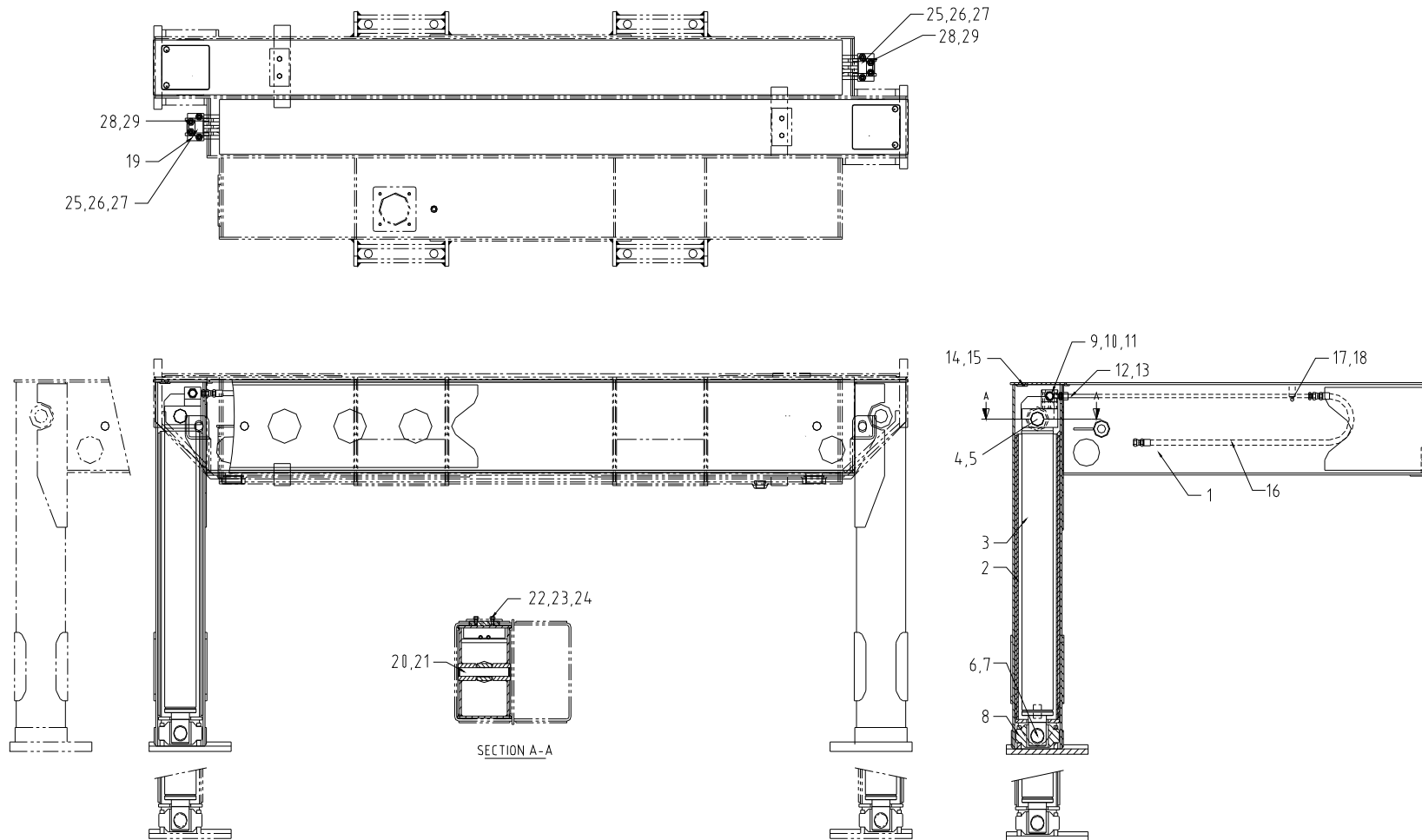

SPARE PARTS LIST



아우트리거 결합체
OUTRIGGER ASS'Y

HIAB190T-6 22:0
2013. 01.

번호 No.	부품 번호 Part No.	품명 Description	수량 Q'ty	비고 Remarks	번호 No.	부품 번호 Part No.	품명 Description	수량 Q'ty	비고 Remarks
20	N01-0932	핀 PIN	2						
21	4525251	멈춤 링 RING, RETAINING	4	RB25					
22	OR1-0009	슬라이드 패드 PAD, SLIDE	2						
23	3612081	스프링 와셔 WASHER, SPRING	4	WS8					
24	2110866	육각 볼트 BOLT, HEX. HEAD	4	BA8×16					
25	OR1-3004	축 SHAFT	2						
26	3511241	평 와셔 WASHER, SEALING	2	WP24					
27	1311321	분할 핀 PIN, SPLIT	2	PW6.3×40					
28	9211062	호스 니플 NIPPLE, PT HOSE	8	NTC6					
29	S01-2291	엘보 스위블 SWIVEL, ELBOW	8	PF1/4					

SPARE PARTS LIST



아우트리거 실린더
OUTRIGGER CYLINDER

HIAB190T-6 23:0
2013. 01.

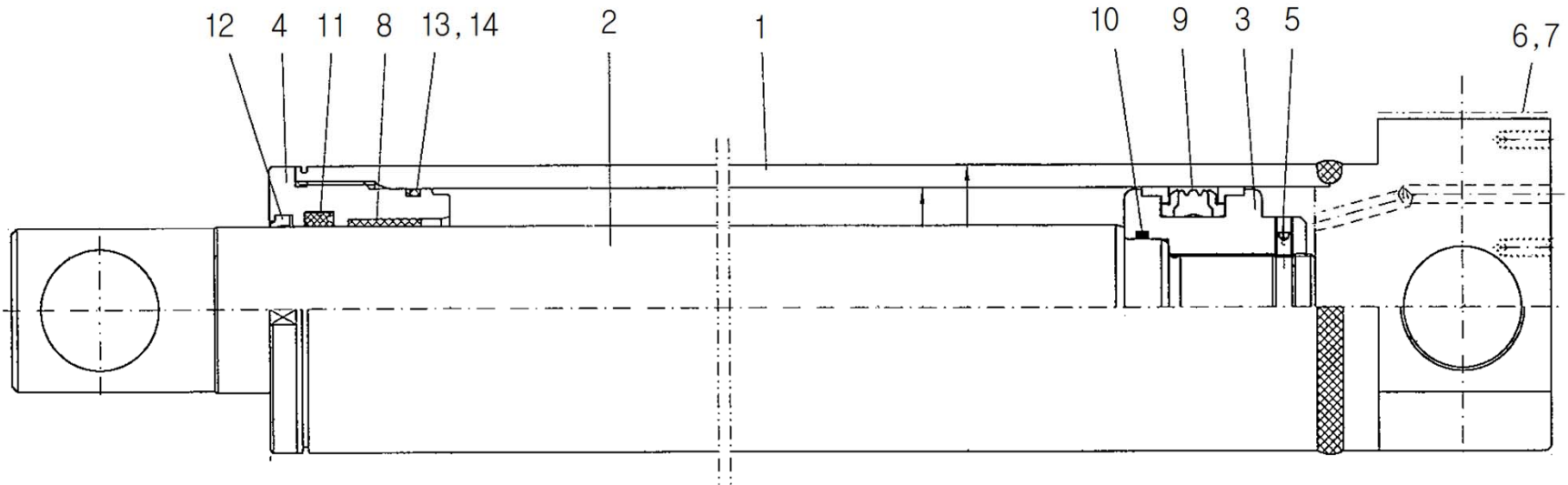

SPARE PARTS LIST



아우트리거 실린더
OUTRIGGER CYLINDER

HIAB190T-6 23:0
2013.01.

번호 No.	부품 번호 Part No.	품명 Description	수량 Q'ty	비고 Remarks	번호 No.	부품 번호 Part No.	품명 Description	수량 Q'ty	비고 Remarks
-	H01-2066 HN25J0A00	아우트리거 실린더 OUTRIGGER CYLINDER	1		10		O-링 O-RING	1	1B G45
1	HN25J0010	튜브 결합체 TUBE ASS'Y	1		11		U-패킹 U-PACKING	1	NI-300 (Φ55×Φ65×10W)
2	HN24J0A10	로드 ROD	1		12		더슬 와이퍼 DUST WIPER	1	KDD 55
3	SH10J8030	피스톤 PISTON	1		13		O-링 O-RING	1	1B G75
4	HN04J0030	로드 커버 COVER, ROD	1		14		백업 링 RING, BACK-UP	1	(T-3) G75
5		멈춤 나사 SCREW, SET	1	M8×P1.25×6L					
6		더스트 커버 DUST COVER	1	50×70×3.2t					
7		육각 볼트 HEX. BOLT	2	M6×P1.0×10L	-	S01-2125	시일 키트 KIT, SEAL	1	
8		부쉬 DU BUSH	1	MB 5525 DU					
9		컴팩트 시일 SEAL, COMPACT	1	PCB 0A0800-NCRO					

SPARE PARTS LIST



사이드 쉬프트 실린더
SIDE SHIFT CYLINDER

HIAB190T-6 24 : 0
2013. 01.

번호 No.	부품 번호 Part No.	품 명 Description	수량 Q'ty	비 고 Remarks	번호 No.	부품 번호 Part No.	품 명 Description	수량 Q'ty	비 고 Remarks
-	H01-1431	사이드 쉬프트 실린더 SIDE SHIFT CYLINDER	1		10	6036751	백업 링 RING, BACK-UP	1	BRT2 30
1	HN21SS010-01	튜브 결합체 TUBE ASS'Y	1		11	6115571	더스트 시일 SEAL, DUST	1	DSI 30
2	HN03SS020	로드 결합체 ROD ASS'Y	1		12	6012292	O-링 O-RING	1	1B G45
3	SS56C0030	피스톤 PISTON	1		13	6035701	백업 링 RING, BACK-UP	1	T3 G45
4	SH17FE040	로드 커버 COVER, ROD	1						
5	4320921	DU 부싱 BUSHING, DU	1	MB3025DU					
6	2350446	멈춤 나사 SCREW, SET	1	BV6×6					
7	6211211	컴팩트 시일 SEAL, COMPACT	1	DAS 50	-	S01-0921	시일 키트 KIT, SEAL	1	
8	6010212	O-링 O-RING	1	1B P18					
9	6513591	U-패킹 U-PACKING	1	ISI 30					

SPARE PARTS LIST



파일로트 체크 밸브 (D)
PILOT CHECK VALVE (D)

HIAB190T-6 25 : 0
2013. 01.

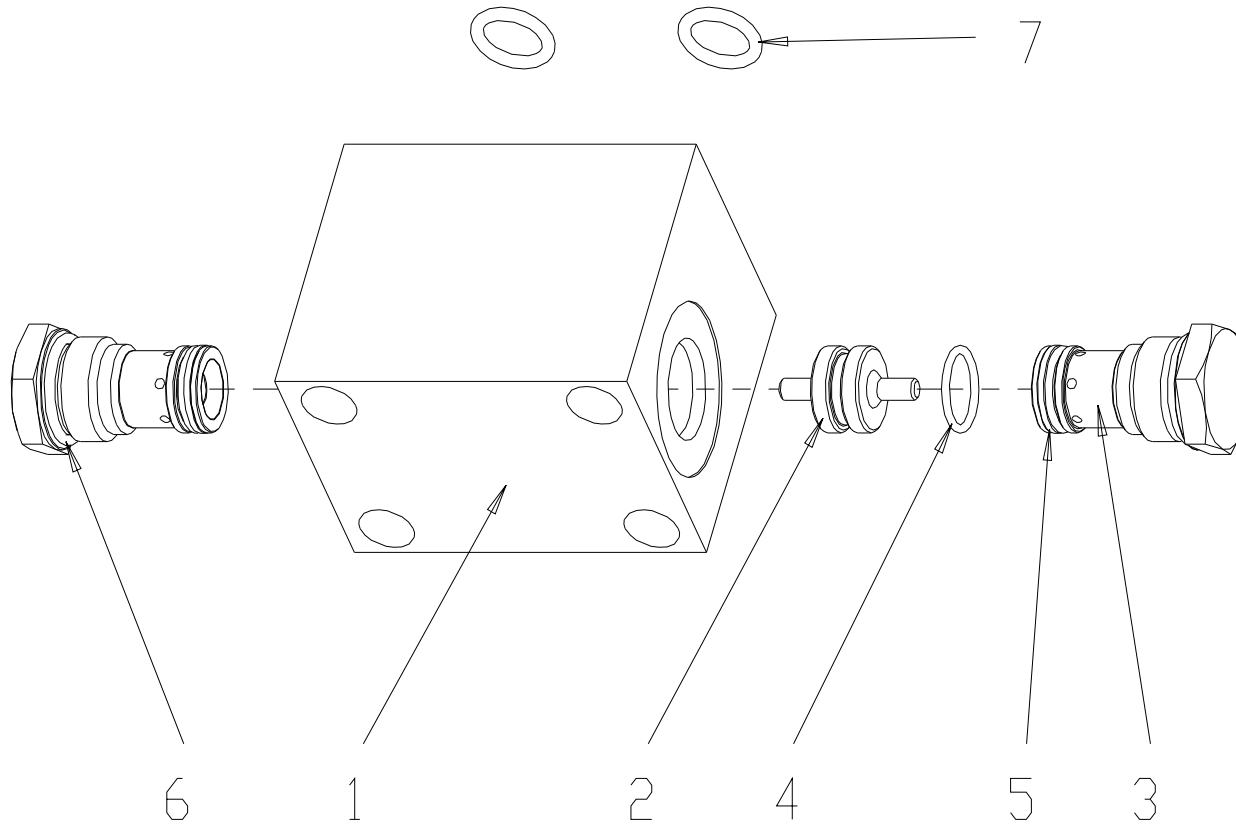

SPARE PARTS LIST



파일로트 체크 밸브 (D)
PILOT CHECK VALVE (D)

HIAB190T-6 25 : 0
2013. 01.

번호 No.	부품 번호 Part No.	품 명 Description	수량 Q'ty	비 고 Remarks	번호 No.	부품 번호 Part No.	품 명 Description	수량 Q'ty	비 고 Remarks
-	H02-1058	파일로트 체크 밸브 VALVE, PILOT CHECK (D)	1						
1	D25-0005-1	블록 BODY, VALVE	1	50×55×73					
2	D25-0005-2	스풀 SPOOL	1						
3	D25-0005-3	체크 밸브 VALVE, CHECK	2						
4	D25-0005-4	오 링 O-RING	3	Φ13×t1.5					
5	D25-0005-5	백업 링 RING, BACK-UP	2	Φ13×t1.2					
6	D25-0005-6	오 링 O-RING	2	Φ16.5×t2.0					
7	6010142	오 링 O-RING	2	P12					

SPARE PARTS LIST



후방 아웃리거 시스템 (옵션)
REAR OUTRIGGER SYSTEM (OPTION)

HIAB190T-6 26 : 0
2013. 01.

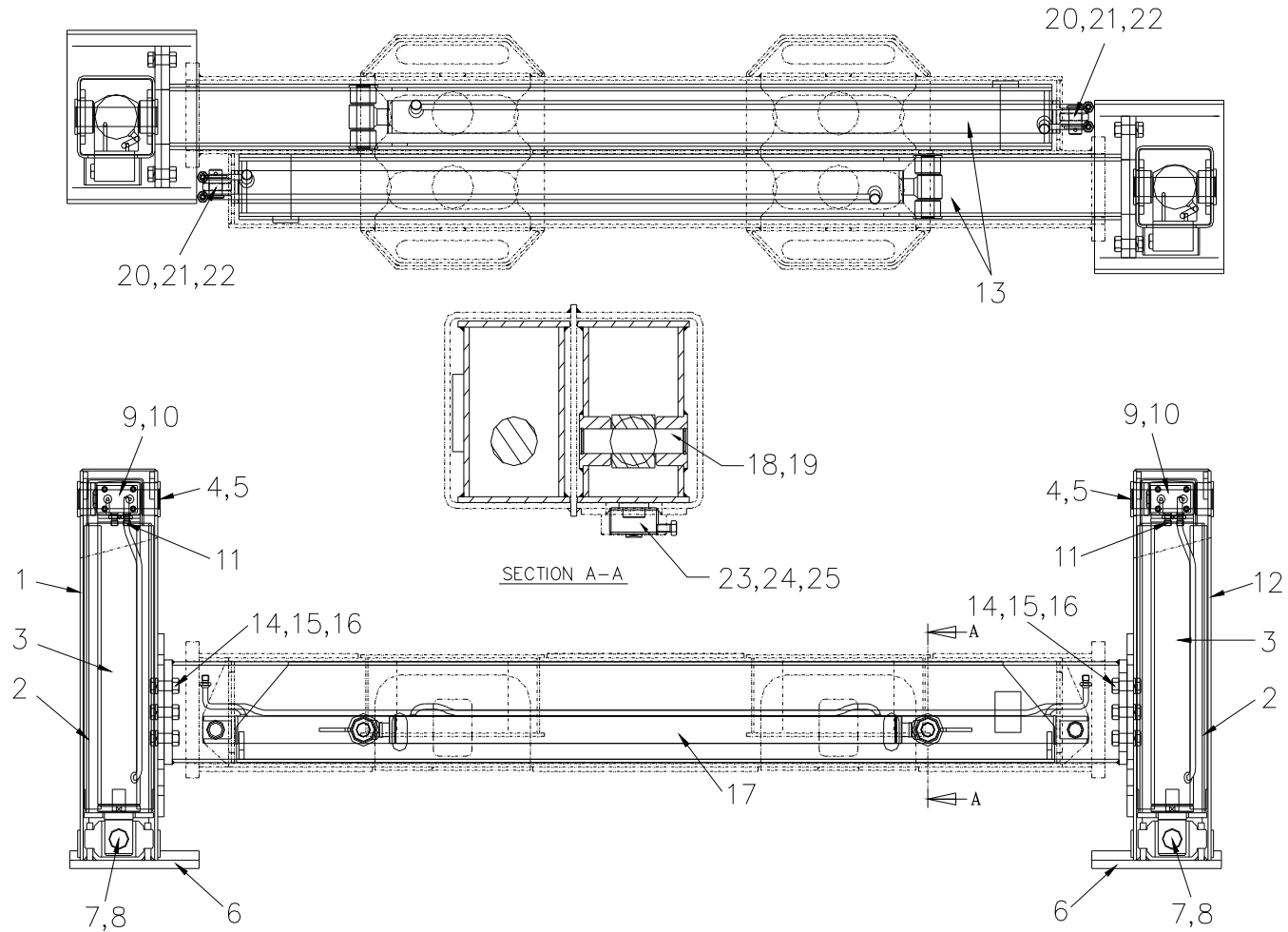

SPARE PARTS LIST



후방 아우트리거 시스템 (옵션)
 REAR OUTRIGGER SYSTEM (OPTION)

HIAB190T-6 26 : 0
 2013. 01.

번호 No.	부품 번호 Part No.	품 명 Description	수량 Q'ty	비 고 Remarks	번호 No.	부품 번호 Part No.	품 명 Description	수량 Q'ty	비 고 Remarks
-	A01-1149	후방 아우트리거 결합체 REAR OUTRIGGER ASS'Y	1		10	2615977	구멍 붙이 육각 볼트 BOLT, HEX. SOCKET HEAD	8	BB6×55
1	A05-2645	외부 튜브 TUBE, OUTER	1	(R.H)	11	9211062	호스 니플 NIPPLE, PT HOSE	4	NTC6
2	A05-0745	내부 튜브 TUBE, INNER	2		12	A05-2644	외부 튜브 TUBE, OUTER	1	(L,H)
3	H01-2062	후방 아우트리거 실린더 결합체 REAR OUTRIGGER CYL'D ASS'Y	2		13	A05-2646	빔 결합체 BEAM ASS'Y	2	
4	S01-3105	축 SHAFT	2	Φ35×150	14	2112167	육각 볼트 BOLT, HEX. HEAD	12	BA16×50
5	4525311	멈춤 링 RING, RETAINING	2	RB35	15	3612161	스프링 와셔 WASHER, SPRING	12	WS16
6	OR2-1010	슈 결합체 SHOE ASSY	2		16	3111167	육각 너트 NUT, HEX.	12	NA16
7	OR-0034	축 SHAFT	2	Φ35	17	H01-2064	후방 사이드 쉬프트 실린더 결합체 REAR SIDE SHIFT CYL'D ASS'Y	2	
8	4510311	멈춤 링 RING, RETAINING	2	RS34	18	S01-0874	핀 PIN	2	Φ25
9	H02-0563	파일럿 체크 밸브 VALVE, PILOT CHECK (D)	2		19	4525251	멈춤 링 RING, RETAINING	4	RB25

SPARE PARTS LIST



후방 아웃리저 시스템 (옵션)
REAR OUTRIGGER SYSTEM (OPTION)

HIAB190T-6 26 : 0
2013. 01.

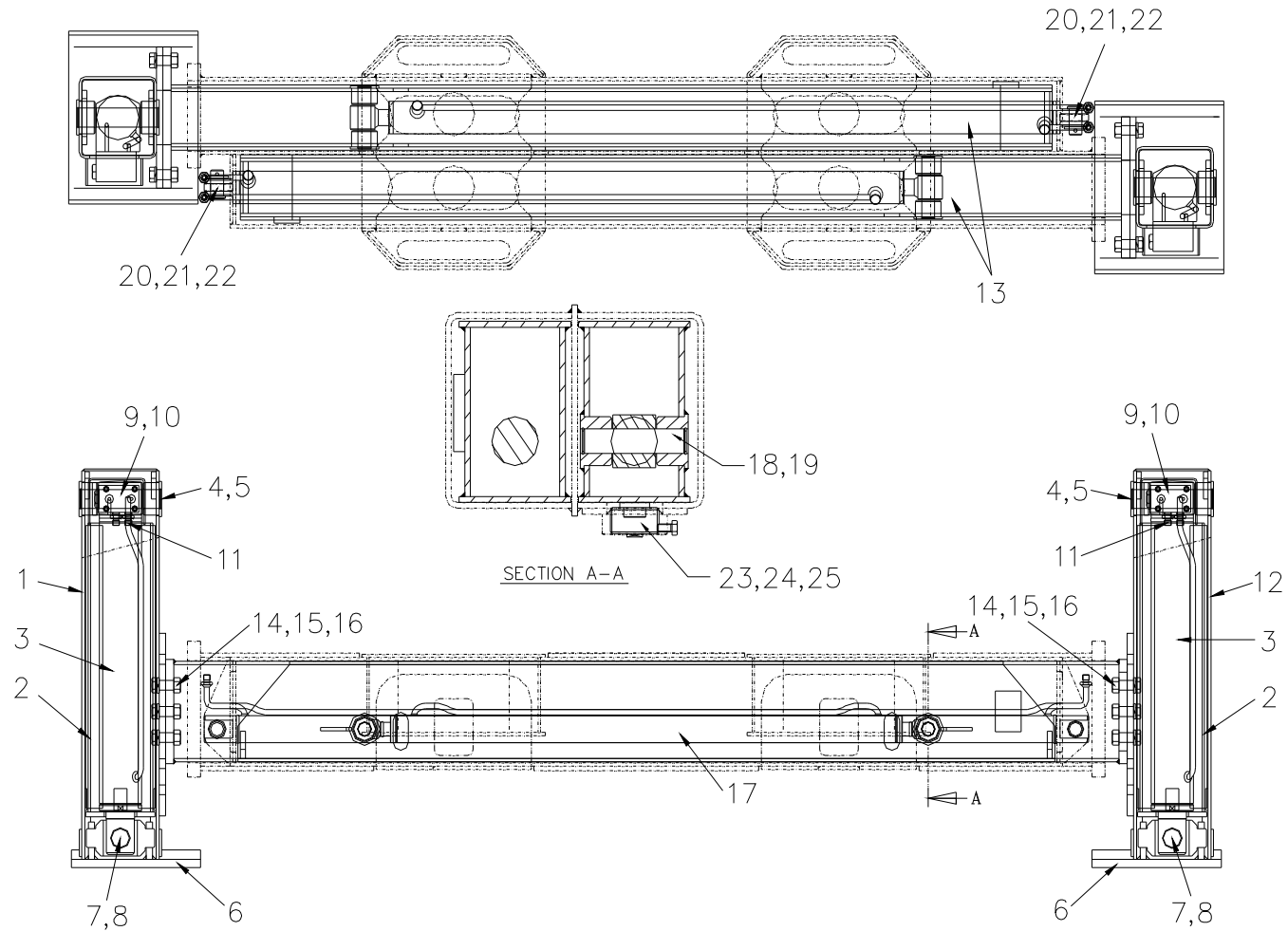

SPARE PARTS LIST



후방 아웃리거 시스템 (옵션)
 REAR OUTRIGGER SYSTEM (OPTION)

HIAB190T-6 26 : 0
 2013. 01.

번호 No.	부품 번호 Part No.	품 명 Description	수량 Q'ty	비 고 Remarks	번호 No.	부품 번호 Part No.	품 명 Description	수량 Q'ty	비 고 Remarks
20	S01-0875	축 SHAFT	2	Φ25					
21	3511241	평 와셔 WASHER, PLAIN	2	WP24					
22	1311321	분할 핀 PIN, SPLIT	2	PW5.9×40					
23	OR-0062	조절 볼트 BOLT, ADJUST	2	M52×45L					
24	OR-0063	조절 패드 PAD, ADJUST	2	Φ48×22					
25	2110906	육각머리 볼트 BOLT, HEX. HEAD	2	BA8×25					

SPARE PARTS LIST



후방 아웃리거 실린더 (옵션)
REAR OUTRIGGER CYLINDER (OPTION)

HIAB190T-6 27:0
2013. 01.

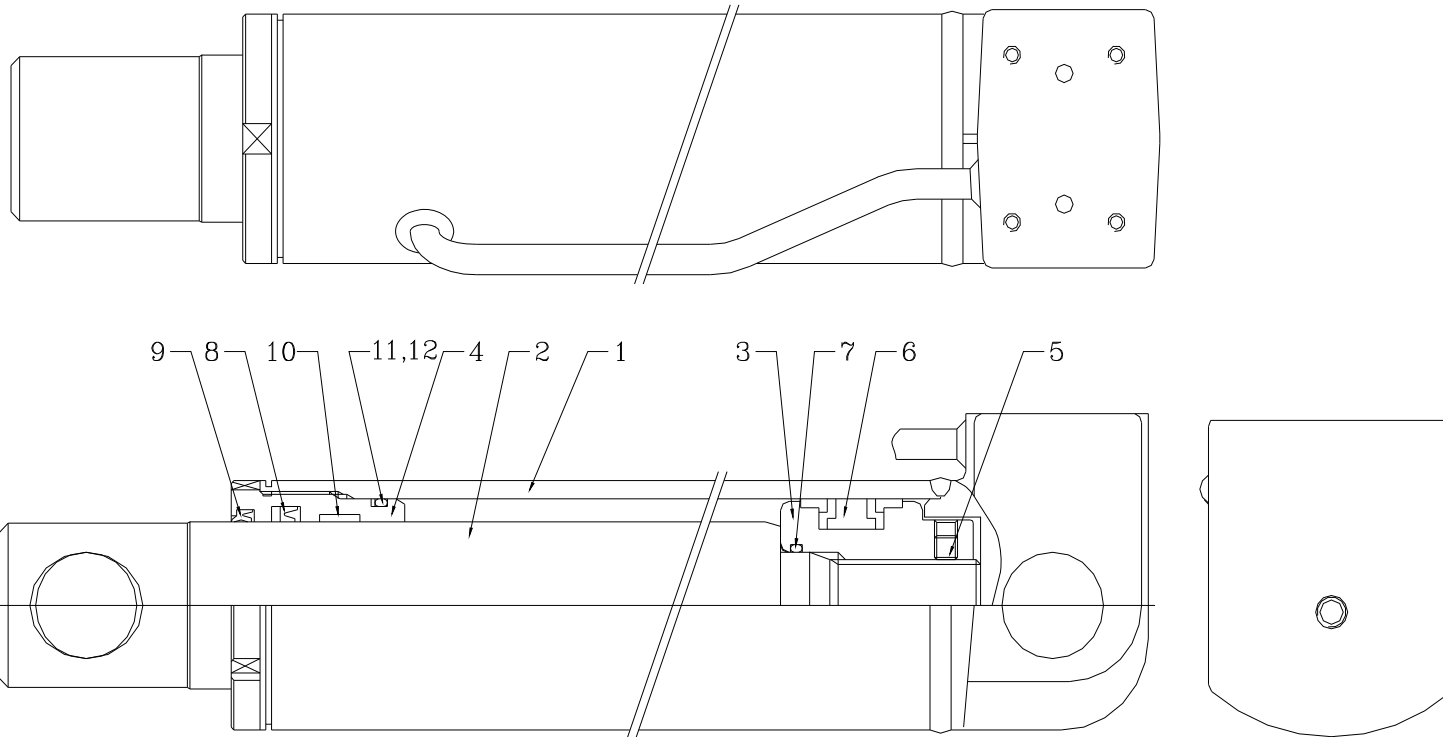

SPARE PARTS LIST



후방 아우트리거 실린더 (옵션)
 REAR OUTRIGGER CYLINDER (OPTION)

HIAB190T-6 27:0
 2013. 01.

번호 No.	부품 번호 Part No.	품명 Description	수량 Q'ty	비고 Remarks	번호 No.	부품 번호 Part No.	품명 Description	수량 Q'ty	비고 Remarks
-	H01-2062	후방 아우트리거 실린더 REAR OUTRIGGER CYLINDER	1		10	S01-0872	웨어 링 RING, WEAR	1	Φ55×Φ60×15
1	HN03RJ010-01	튜브 결합체 TUBE ASS'Y	1		11	6012332	O-링 O-RING	1	1B G65
2	HN03RJ020-01	로드 ROD	1		12	6035741	백업 링 RING, BACK-UP	1	T3 G65
3	KL08FJ030	피스톤 PISTON	1	M35×P1.5					
4	KL08FJ040	로드 커버 COVER, ROD	1	M74×P1.5					
5	2350496	멈춤 나사 SCREW, SET	1	BV6×16	-	S01-2122	시일 키트 KIT, SEAL	1	
6	6211331	컴팩트 시일 SEAL, COMPACT	1	DAS 70					
7	6012282	O-링 O-RING	1	1B G40					
8	6513691	유 패킹 U-PACKING	1	NI-300					
9	6115651	더스트 시일 SEAL, DUST	1	KDD 55					

SPARE PARTS LIST



후방 사이드 쉬프트 실린더 (옵션)
REAR SIDE SHIFT CYLINDER (OPTION)

HIAB190T-6 28:0
2013. 01.

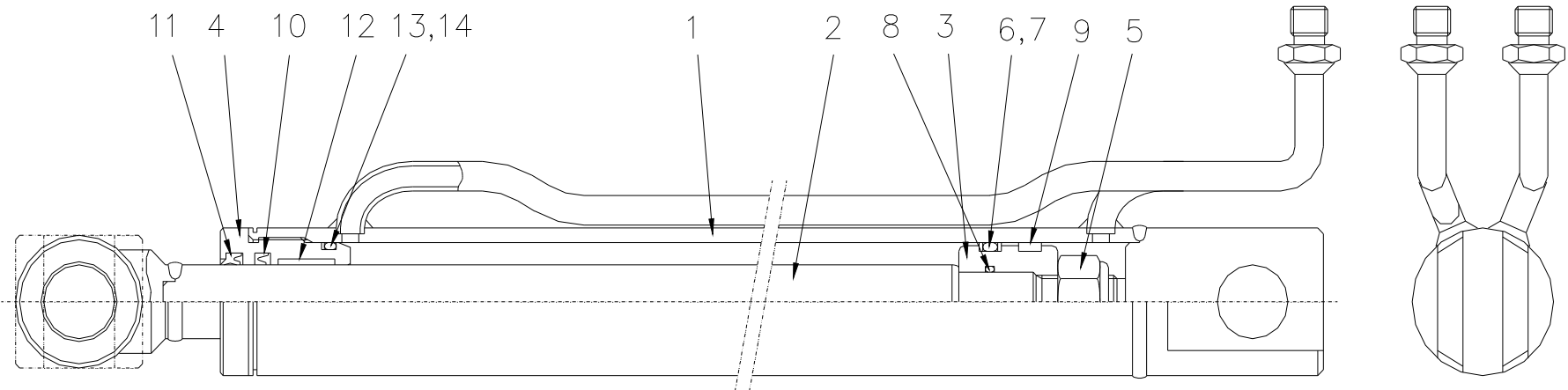

SPARE PARTS LIST



후방 사이드 쉬프트 실린더 (옵션)
REAR SIDE SHIFT CYLINDER (OPTION)

HIAB190T-6 28:0
2013. 01.

번호 No.	부품 번호 Part No.	품명 Description	수량 Q'ty	비고 Remarks	번호 No.	부품 번호 Part No.	품명 Description	수량 Q'ty	비고 Remarks
-	H01-2064	후방 사이드 쉬프트 실린더 REAR SIDE SHIFT CYLINDER	1	HN03RS000-02	10		로드 시일 ROD SEAL	1	NI-300
1	HN03RS010	튜브 결합체 TUBE ASS'Y	1		11	6115551	더스트 시일 SEAL, DUST	1	KDD 25
2	HN03RS020-01	로드 결합체 ROD ASS'Y	1		12	S01-0910	웨어 링 RING, WEAR	1	Φ25×Φ29×20W
3	KL08LS030	피스톤 PISTON	1		13	6010402	O-링 O-RING	1	1B G35
4	SS35AE040-01	로드 커버 COVER, ROD	1		14	6035681	백업 링 RING, BACK UP	1	T3 G35
5		라일론 너트 NUT, NYLON	1	M18×P2.5					
6	6010392	O-링 O - RING	1	1B P34					
7	6032361	백업 링 RING, BACK UP	2	T2 P34	-	S01-2124	시일 키트 KIT, SEAL	1	
8	6010222	O-링 O-RING	1	1B P20					
9	S01-0648	웨어 링 RING, WEAR	1	Φ40×Φ35×9.5W					

SPARE PARTS LIST



파일럿 체크 밸브 (옵션)
PILOT CHECK VALVE (D) (OPTION)

HIAB190T-6 29:0
2013. 01.

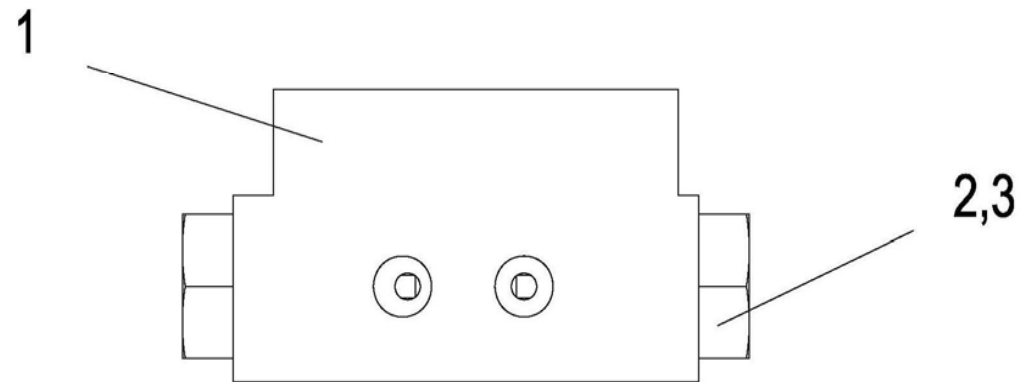
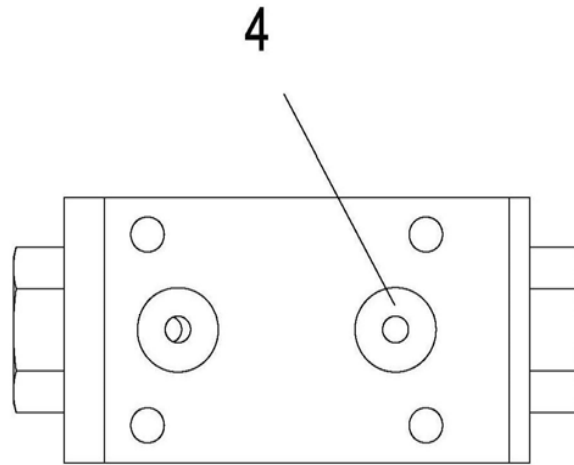

SPARE PARTS LIST



파일럿 체크 밸브 (옵션)
PILOT CHECK VALVE (D) (OPTION)

HIAB190T-6 29:0
2013. 01.

번호 No.	부품 번호 Part No.	품 명 Description	수량 Q'ty	비 고 Remarks	번호 No.	부품 번호 Part No.	품 명 Description	수량 Q'ty	비 고 Remarks
-	H02-0563	파일럿 체크 밸브 VALVE, PILOT CHECK	1						
1		블럭 BLOCK	1						
2		스풀 SPOOL	1						
3		체크 밸브 CHECK VALVE	2						
4		오 링 O-RING	2						

SPARE PARTS LIST



전기 배선도 ELECTRIC WIRING DIAGRAM

HIAB190T-6 30 : 0
2013. 01.

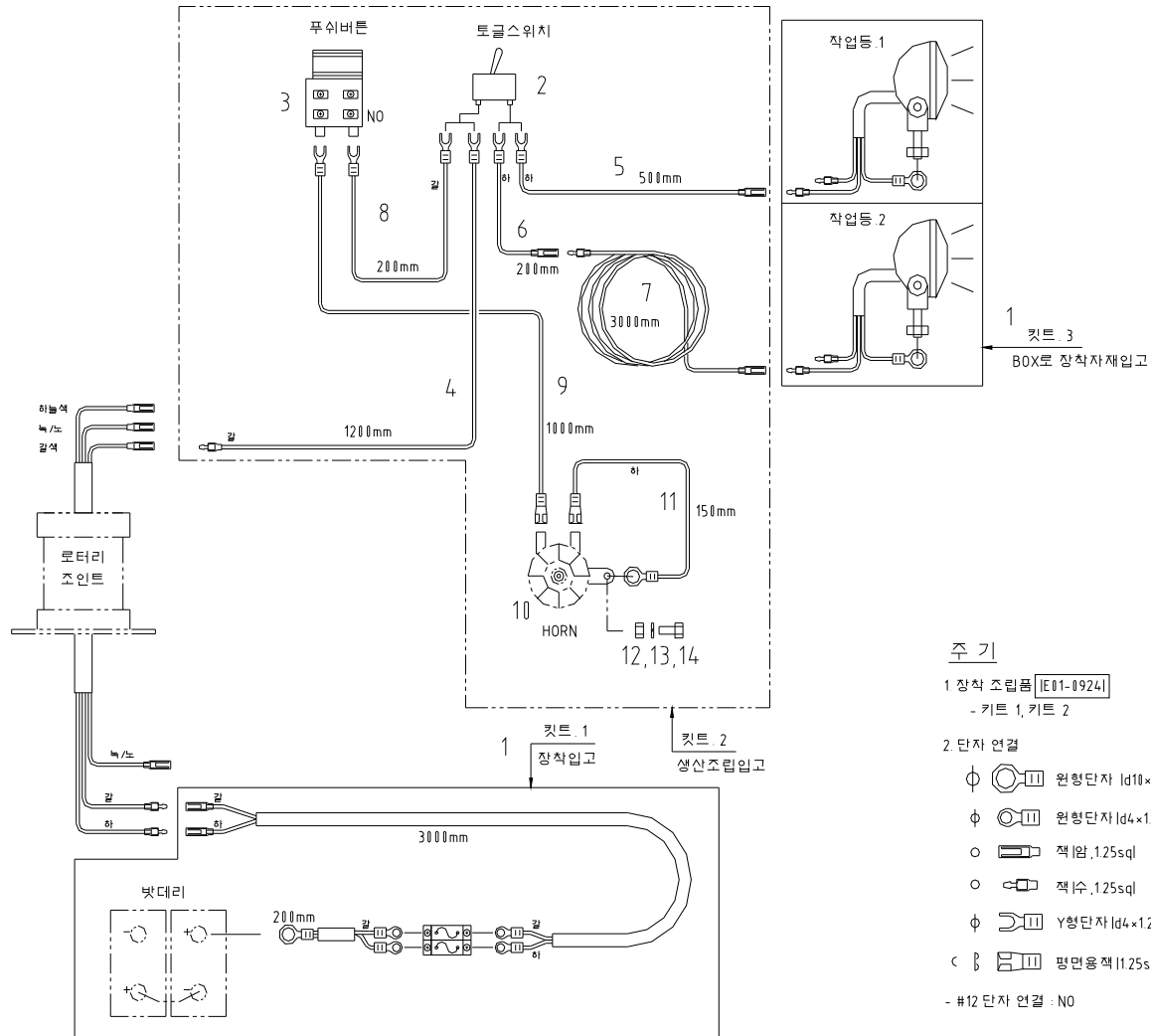

주 기

1. 장착 조립품 [E01-0924]

- 키트 1, 키트 2

2. 단자 연결

φ ○ □ 원형단자 | d10×1.25sq |

φ ○ □ 원형단자 | d4×1.25sq |

○ □ 잭 | 1.25sq |

○ □ 잭 | 1.25sq |

φ □ Y형단자 | d4×1.25sq |

< β □ 평면용잭 | 1.25sq |

- #12 단자 연결 : NO

SPARE PARTS LIST



전기 배선도
ELECTRIC WIRING DIAGRAM

HIAB190T-6 30 : 0
2013. 01.

번호 No.	부품 번호 Part No.	품 명 Description	수량 Q`ty	비 고 Remarks	번호 No.	부품 번호 Part No.	품 명 Description	수량 Q`ty	비 고 Remarks
-	E00-0116	전기배선도 ELECTRIC WIRING DIAGRAM	1		10	E01-0082	혼 HORN	1	*
1	E01-0924	전기 와이어 결합체 ELEC. WIRE ASS'Y	1		11	E01-0918	전기 와이어 결합체 ELEC. WIRE ASS'Y	1	1.5SQ *
2	E01-0053	토글 스위치 S/W, TOGGLE	1	*	12	2115906	육각머리 볼트 BOLT, HEX. HEAD	1	BA8×25 *
3	E01-0095	푸쉬 버튼 스위치 S/W, PUSH BUTTON	1	*	13	3612081	스프링 와셔 WASHER, SPRING	1	WS8 *
4	E01-0912	전기 와이어 결합체 ELEC. WIRE ASS'Y	1	1.5SQ *	14	3111086	육각 너트 NUT, HEX.	1	NA8 *
5	E01-0913	전기 와이어 결합체 ELEC. WIRE ASS'Y	1	1.5SQ *					
6	E01-0914	전기 와이어 결합체 ELEC. WIRE ASS'Y	1	1.5SQ *	-	E01-1181	전기 결합체 ELEC. ASS'Y	1	PARTS MARKED *
7	E01-0915	전기 와이어 결합체 ELEC. WIRE ASS'Y	1	1.5SQ *					
8	E01-0916	전기 와이어 결합체 ELEC. WIRE ASS'Y	1	1.5SQ *					
9	E01-0917	전기 와이어 결합체 ELEC. WIRE ASS'Y	1	1.5SQ *					

SPARE PARTS LIST



스티커 배열 STICKER ARRANGEMENT

HIAB190T-6 31 : 0
2013. 01.

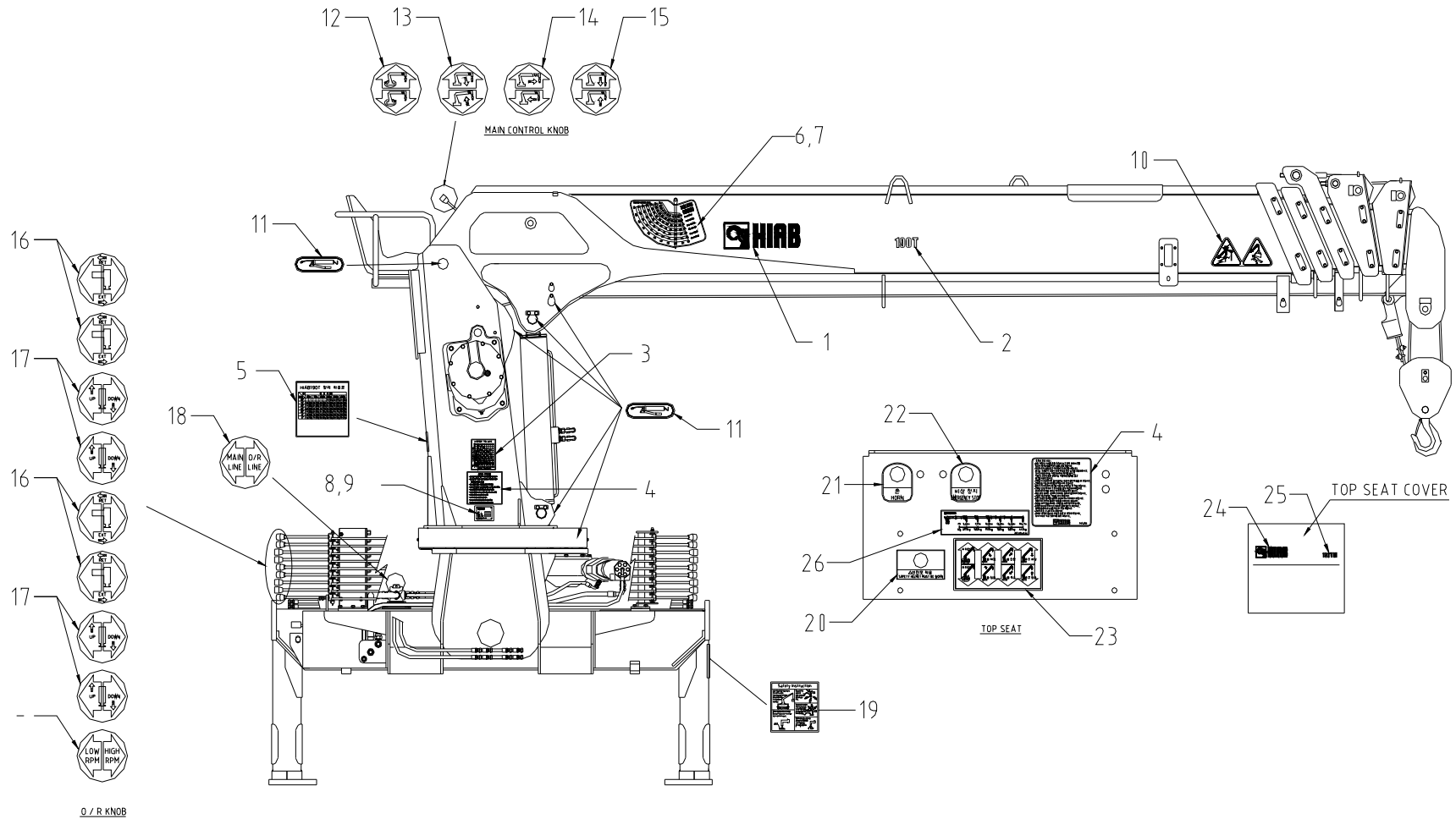

SPARE PARTS LIST



스티커 배열
STICKER ARRANGEMENT

HIAB190T-6 31:0
2013. 01.

번호 No.	부품 번호 Part No.	품명 Description	수량 Q'ty	비고 Remarks	번호 No.	부품 번호 Part No.	품명 Description	수량 Q'ty	비고 Remarks
-	A01-3270	스티커 배열 ARRANGENT, STICKER	1		10	P01-0124	위험 플레이트 PLATE, WARNING	2	
1	387 0370	로고 라벨 LABEL, LOGO	2		11	P01-0159	그리스 스티커 STICKER, GREASE	7	
2	161 8342	모델 네임 라벨 LABEL, MODEL NAME	2		12	P01-0258	컨트롤 플레이트 PLATE, CONTROL	2	SLEWING
3	P01-0373	작업 반경도 WORKING RADIUS	1		13	P01-0259	컨트롤 플레이트 PLATE, CONTROL	2	DERRICK
4	P01-0272	주의사항 라벨 LABEL, WARNING	1		14	P01-0260	컨트롤 플레이트 PLATE, CONTROL	2	EXTENSION
5	P01-2217	적재 능력 LOAD CHART	1		15	P01-0261	컨트롤 플레이트 PLATE, CONTROL	2	WINCH
6	P01-2030	붐 각도 플레이트(오른쪽) PLATE, BOOM ANGLE(RIGHT)	1		16	P01-0264	사이드 쉬프트 스티커 STICKET, SIDE SHIFT	8	
7	P01-2031	붐 각도 플레이트(왼쪽) PLATE, BOOM ANGLE(LEFT)	1		17	P01-0265	아웃트리거 스티커 STICKER, JACK	8	
8	P01-0630	명칭 플레이트 PLATE, NAME	1		18	P01-2066	라인 컨트롤 스티커 STICKER, LINE CONTROL	2	
9	S01-0182	블라인드 리벳 RIVET, BLIND	4		19	P01-0358	아웃트리거 위험 플레이트 PLATE, O/R WARNING	2	

SPARE PARTS LIST



스티커 배열 STICKER ARRANGEMENT

HIAB190T-6 31 : 0
2013. 01.

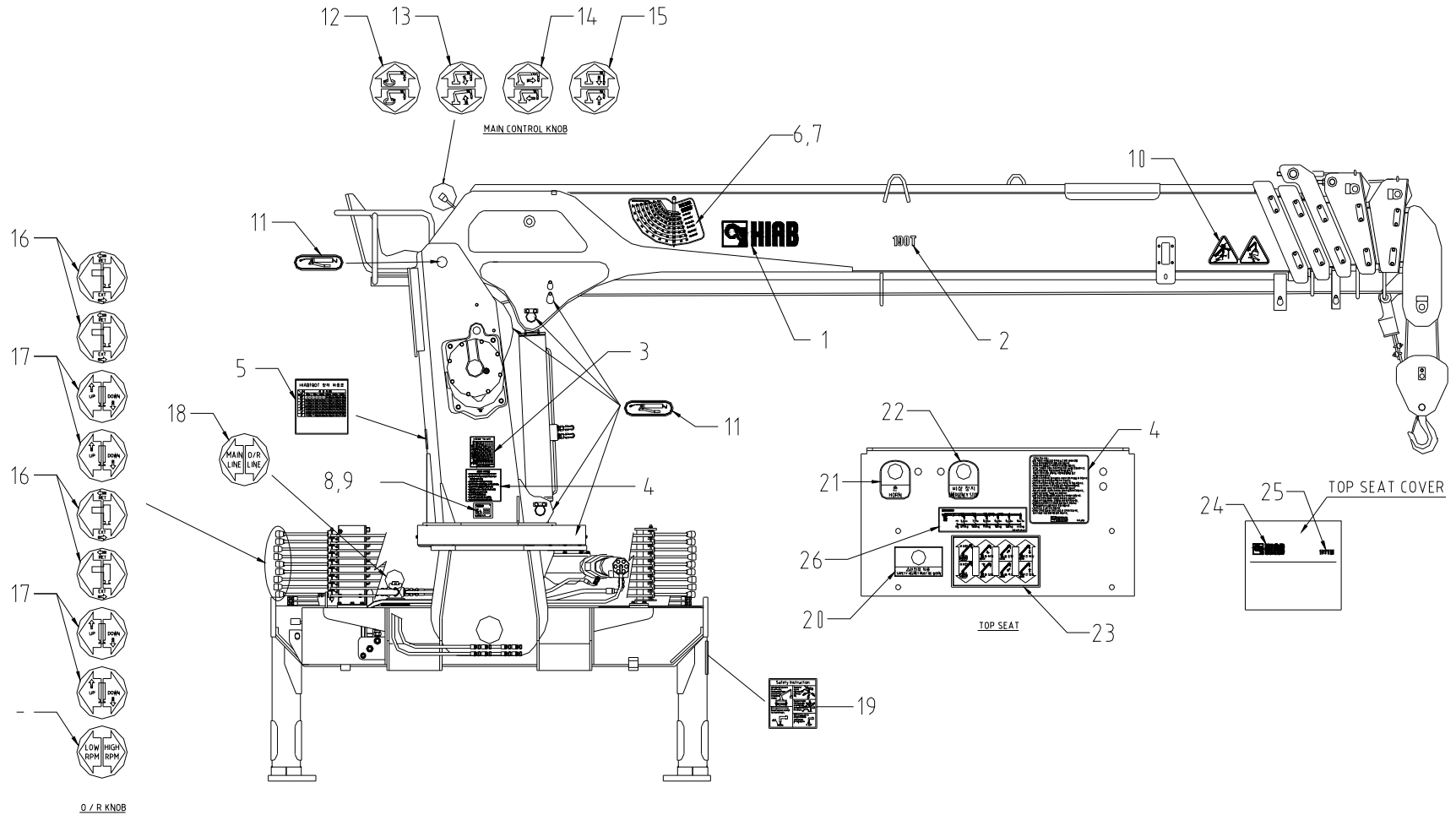

SPARE PARTS LIST



스티커 배열
STICKER ARRANGEMENT

HIAB190T-6 31 : 0
2013. 01.

번호 No.	부품 번호 Part No.	품 명 Description	수량 Q`ty	비 고 Remarks	번호 No.	부품 번호 Part No.	품 명 Description	수량 Q`ty	비 고 Remarks
20	P01-2044	안전모 착용 스티커 STICKER, SAFETY HELMET	1						
21	P01-2132	경적 스티커 STICKER, HORN	1						
22	P01-2133	비상 정지 스티커 STICKER, EMERGENCY STOP	1						
23	P01-0273	컨트롤 스티커 STICKER, CONTROL	1						
24	112768401	로고 라벨 LABEL, LOGO	1						
25	161 8849	모델 네임 라벨 LABEL, MODEL NAME	1						
26	P01-2512	하중능력 스티커 STICKER, CAPACITY	1						

SPARE PARTS LIST



오일 탱크
OIL TANK

HIAB190T-6 32 : 0
2013. 01.

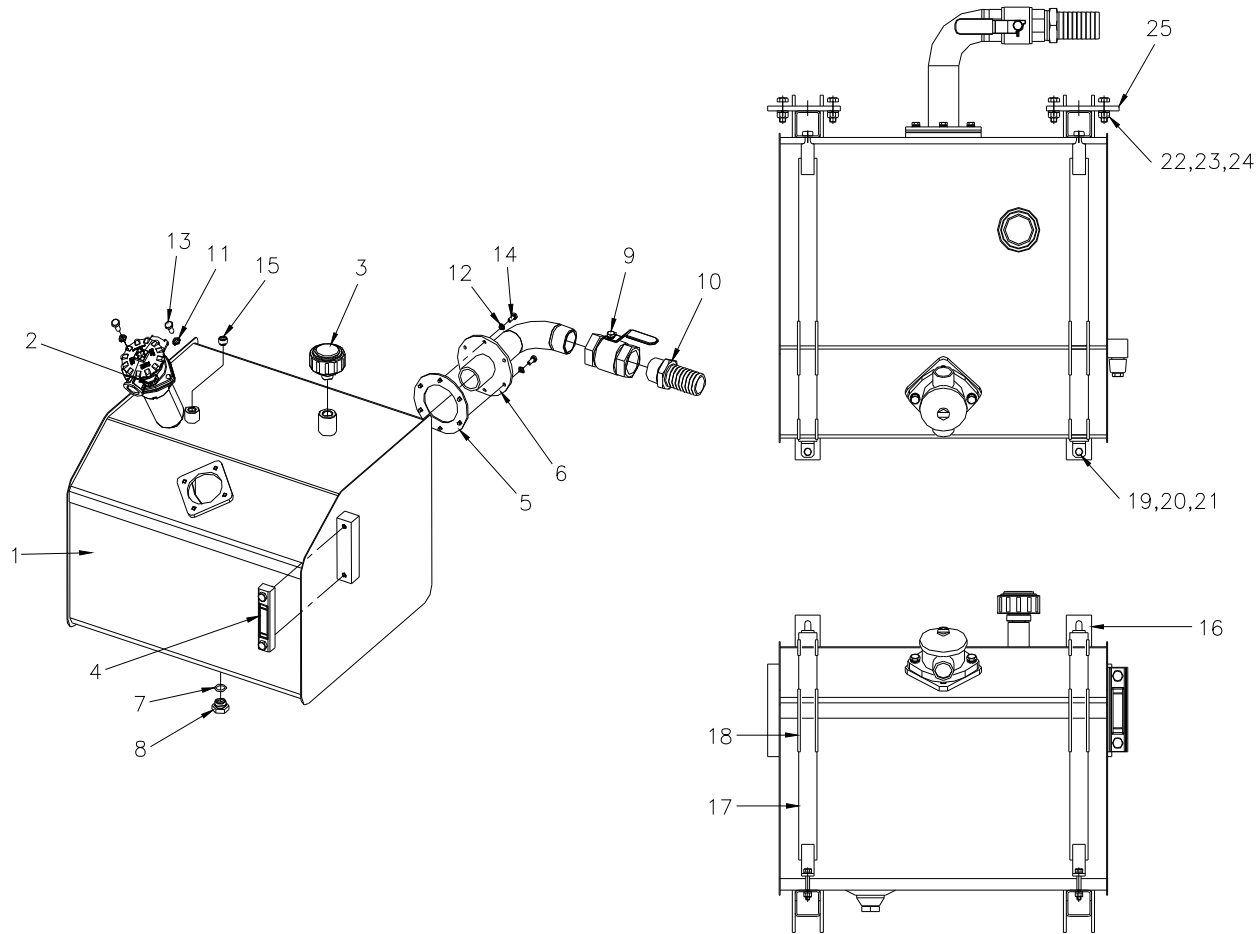

SPARE PARTS LIST



오일 탱크
OIL TANK

HIAB190T-6 32 : 0
2013. 01.

번호 No.	부품 번호 Part No.	품 명 Description	수량 Q'ty	비 고 Remarks	번호 No.	부품 번호 Part No.	품 명 Description	수량 Q'ty	비 고 Remarks
-	A02-0950	오일 탱크 조립체 OIL TANK ASS'Y	1	170 ℓ	10	S01-0741	석션 니플 NIPPLE, SUCTION	1	PT2,O,Φ52
1	A05-3260	오일 탱크 바디 BODY, OIL TANK	1		11	3612101	스프링 와셔 WASHER, SPRING	2	WS10
2	H01-1287	리턴 필터 FILTER, RETURN	1		12	3612081	스프링 와셔 WASHER, SPRING	6	WS8
3	S01-2475	에어 브리더 BREATHER, AIR	1	BF30	13	2111206	육각 볼트 BOLT, HEX. HEAD	2	BA10×25
4	S01-2474	오일 레벨 게이지 GUAGE, OIL LEVEL	1	FSA	14	2110886	육각 볼트 BOLT, HEX. HEAD	6	BA8×20
5	OT-0013	가스켓 GASKET	1	t4, Φ150	15	BA-0079	플러그 PLUG, PT	1	PT 1/2
6	A05-1570	흡입 플랜지 FLANGE, SUCTION	1	PT2"×50A	16	A05-3261	마운팅 브라켓 BRACKET, TANK	2	
7	6010282	O- 링 O-RING	1	P24	17	A05-3262	오일 탱크 밴드 OIL TANK BAND	2	
8	S01-0076	플러그 PLUG	1	PF3/4	18	S01-0046	밴드 BAND	4	
9	S01-0740	핸드 스톱 밸브 VALVE, HAND STOP	1	2-PT2"	19	2115976	육각 볼트 BOLT, HEX. HEAD	2	BA8×55

SPARE PARTS LIST



오일 탱크
OIL TANK

HIAB190T-6 32 : 0
2013. 01.

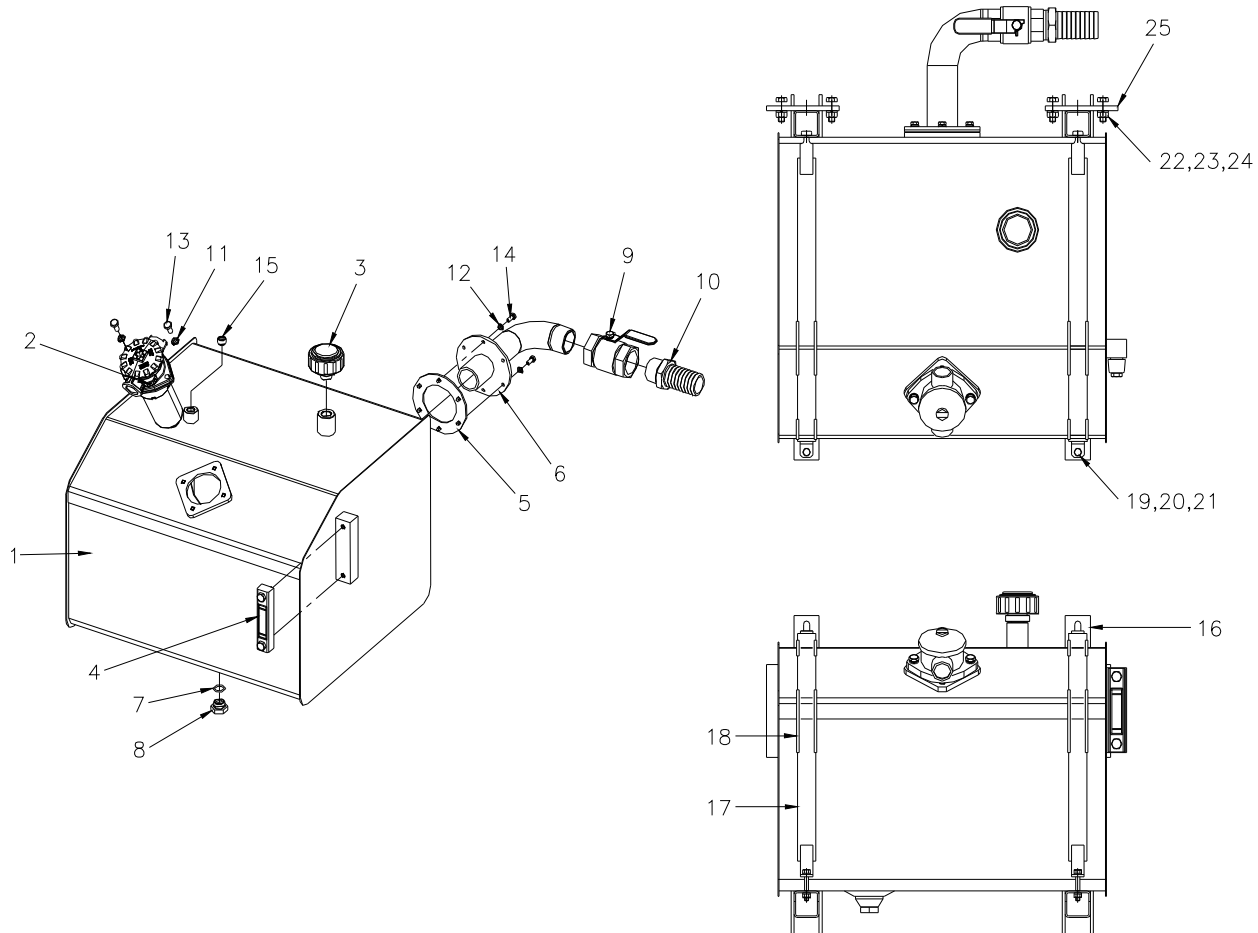

SPARE PARTS LIST



오일 탱크
OIL TANK

HIAB190T-6 32 : 0
2013. 01.

번호 No.	부품 번호 Part No.	품 명 Description	수량 Q`ty	비 고 Remarks	번호 No.	부품 번호 Part No.	품 명 Description	수량 Q`ty	비 고 Remarks
20	3511081	평 와셔 WASHER, PLAIN	4	WP8					
21	3111081	육각 너트 NUT, HEX.	2	NA8					
22	2111546	육각 볼트 BOLT, HEX. HEAD	8	BA12×40					
23	3612121	스프링 와셔 WASHER, SPRING	8	WS12					
24	3111121	육각 너트 NUT, HEX.	8	NA12					
25	W01-5641	플레이트 PLATE	2	t9					

SPARE PARTS LIST

All rights reserved.
No parts of this publication may be reproduced or copied
in any form or by any means without written permission
of Cargotec Korea Ltd.



Cargotec Korea Ltd

64 Hwangtanri-Gil, Gangnae-Myeon, Heungdeok-Gu,
Cheongju Chungbuk 363-893 South Korea.

Tel : +82 43 231 6300

Fax : +82 43 231 6200

www.cargotec.com